

Operating Instructions

Printer Reference

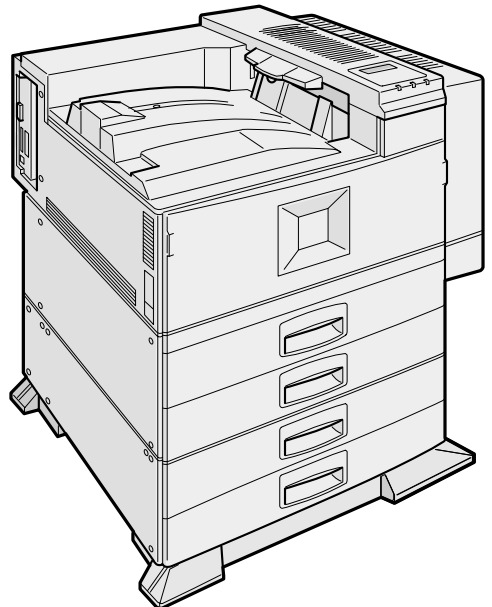

For safety, please read this manual carefully before you use this product and keep it handy for future reference.

Introduction

This manual contains detailed instructions on the operation and maintenance of this machine. To get maximum versatility from this machine all operators should carefully read and follow the instructions in this manual. Please keep this manual in a handy place near the machine.

Please read the Safety Information before using this machine. It contains important information related to USER SAFETY and PREVENTING EQUIPMENT PROBLEMS.

Important

Contents of this manual are subject to change without prior notice. In no event will the company be liable for direct, indirect, special, incidental, or consequential damages as a result of handling or operating the machine.

Caution:

Use of controls or adjustment or performance of procedures other than those specified in this manual might result in hazardous radiation exposure.

Do not attempt any maintenance or troubleshooting other than that mentioned in this manual. This machine contains a laser beam generator and direct exposure to laser beams can cause permanent eye damage.

Two kinds of size notation are employed in this manual. With this machine refer to the inch version.

Supplier shall not be responsible for any damage or expense that might result from the use of parts other than genuine supplier's parts in your supplier's office product.

For good image quality, supplier recommends that you use genuine supplier's toner.

Trademarks

Microsoft, Windows and Windows NT are registered trademarks of Microsoft Corporation in the United States and/or other countries.

Novell, Netware, NDS are registered trademarks of Novell, Inc.

PostScript is a registered trademark of Adobe Systems, Incorporated.

PCL is a registered trademark of Hewlett-Packard Company.

AppleTalk, Apple, Macintosh, TrueType and LaserWriter are registered trademarks of Apple Computer, Incorporated.

IPS-PRINT Printer Language Emulation Copyright© 1999-2000 Oak Technology, Inc., All rights reserved.

Ethernet is a registered trademark of Xerox Corporation.

Other product names used herein are for identification purposes only and might be trademarks of their respective companies. We disclaim any and all rights in those marks.

- The product name of Windows[®] 95 is Microsoft[®] Windows[®] 95.
- The product name of Windows[®] 98 is Microsoft[®] Windows[®] 98.
- The product name of Windows[®] Me is Microsoft[®] Windows[®] Millennium Edition (Windows Me).
- The product names of Windows[®] 2000 are as follows:
 - Microsoft[®] Windows[®] 2000 Advanced Server
 - Microsoft[®] Windows[®] 2000 Server
 - Microsoft[®] Windows[®] 2000 Professional
- The product names of Windows NT[®] 4.0 are as follows:
 - Microsoft[®] Windows NT[®] Server 4.0
 - Microsoft[®] Windows NT[®] Workstation 4.0

Notes:

Some illustrations in this manual might be slightly different from the machine. Certain options might not be available in some countries. For details, please contact your local dealer.

Manuals for This Printer

Manuals for This Printer

The following manuals describe the operational procedures and maintenance of this machine.

To enhance safe and efficient operation of this printer, all users should read and follow the instructions carefully.

❖ **Quick Installation Guide**

Describes how to install the printer.

❖ **Setup Guide**

Provides information about setting up the printer and its options. This manual is provided as a printed manual, and also as a PDF file on the CD-ROM labeled "Operating Instructions".

❖ **Printer Reference (this manual)**

Provides information about using the printer and its options. This manual is provided as a PDF file on the CD-ROM labeled "Operating Instructions".

❖ **Network Printing Guide**

Provides information about setting up and using the printer in a network environment. This manual is provided as a PDF file on the CD-ROM labeled "Operating Instructions".

❖ **PostScript 3 Operating Instructions Supplement**

Describes the menus and features for the PostScript 3 printer driver. This manual is provided as a PDF file on the CD-ROM labeled "Operating Instructions".

 **Note**

- ❑ There are three CD-ROMs that come with this printer. "Operating Instructions", "Printer Drivers and Utilities", and "Document Management Utility".
- ❑ Concerning UNIX information, please visit our web site or consult your authorized reseller.

How to Read This Manual

Symbols

In this manual, the following symbols are used:

 **WARNING:**

This symbol indicates a potentially hazardous situation which, if instructions are not followed, could result in death or serious injury.

 **CAUTION:**

This symbol indicates a potentially hazardous situation which, if instructions are not followed, may result in minor or moderate injury or damage to property.

* The statements above are notes for your safety.

 **Important**

If this instruction is not followed, paper might be misfed, originals might be damaged, or data might be lost. Be sure to read this.

 **Preparation**

This symbol indicates the prior knowledge or preparations required before operating.

 **Note**

This symbol indicates precautions for operation, or actions to take after misoperation.

 **Limitation**

This symbol indicates numerical limits, functions that cannot be used together, or conditions in which a particular function cannot be used.

 **Reference**

This symbol indicates a reference.

[]

Keys that appear on the machine's panel display.

Keys and buttons that appear on the computer's display.

[]

Keys built into the machine's control panel.

Keys on the computer's keyboard.

TABLE OF CONTENTS

1. Setting Up the Printer Driver and Canceling a Print Job

PCL 6/5e - Accessing the Printer Properties	1
Windows 95/98/Me - Accessing the Printer Properties	1
Windows 2000 - Accessing the Printer Properties	2
Windows NT 4.0 - Accessing the Printer Properties	3
RPCS - Accessing the Printer Properties.....	5
Windows 95/98/Me - Accessing the Printer Properties	5
Windows 2000 - Accessing the Printer Properties	6
Windows NT 4.0 - Accessing the Printer Properties	7
PostScript - Setting Up for Printing	9
Windows 95/98/Me - Accessing the Printer Properties	9
Windows 2000 - Accessing the Printer Properties	10
Windows NT 4.0 - Accessing the Printer Properties	11
Macintosh - Setting Up for Printing	13
Canceling a Print Job.....	14
Windows 95/98/Me - Canceling a Print Job	14
Windows 2000 - Canceling a Print Job	15
Windows NT 4.0 - Canceling a Print Job	16
Macintosh - Canceling a Print Job	17

2. Uninstalling the Printer Driver and Software

Uninstalling the PCL 6/5e Printer Driver	19
Windows 95/98/Me - Uninstalling the PCL 6/5e Printer Driver.....	19
Windows 2000 - Uninstalling the PCL 6/5e Printer Driver.....	19
Windows NT 4.0 - Uninstalling the PCL 6/5e Printer Driver.....	20
Uninstalling the RPCS Printer Driver.....	21
Windows 95/98/Me - Uninstalling the RPCS Printer Driver.....	21
Windows 2000 - Uninstalling the RPCS Printer Driver.....	21
Windows NT 4.0 - Uninstalling the RPCS Printer Driver.....	22
Uninstalling the PostScript Printer Driver.....	23
Windows 95/98/Me - Uninstalling the PostScript Printer Driver	23
Windows 2000 - Uninstalling the PostScript Printer Driver	23
Windows NT 4.0 - Uninstalling the PostScript Printer Driver	24

3. Paper and Other Media

Paper and Other Media Supported by This Printer	25
Paper Sizes	25
Paper Recommendations	29
Loading Paper and Other Media	33
Loading Paper in the Paper Tray	33
Loading Paper in the Optional Paper Bank	36
Loading Paper in the Bypass Tray	39
Specifying a Custom Paper Size for the Bypass Tray	41
Loading Paper in the Optional Large Capacity Tray	42

4. Sample Print/Locked Print

Sample Print.....	45
Printing a Sample Print File.....	45
Deleting a Sample Print File.....	47
Checking the Error Log	48
Locked Print.....	49
Printing a Locked Print File	49
Deleting the Locked Print File	51
Checking the Error Log	52

5. Troubleshooting

Error & Status Messages on the Control Panel.....	55
Getting Printer Information over the Network.....	67
Printer Does Not Print.....	75
Other Printing Problems	78
Removing Misfed Paper.....	80
When "Remove Misfeed A,Y:Input Tray" Appears	80
When "Remove Misfeed B,C,D:Internal" Appears	82
When "Remove Misfeed R:Finisher" Appears	84
When "Remove Misfeed U:LCT" Appears	86
When "Remove Misfeed W:Mailbox" Appears	87
When "Remove Misfeed Z:Duplex Unit" Appears	89
Adding Staples	91
Finisher SR720	91
Finisher SR730	92
Removing Jammed Staples.....	94
Finisher SR720	94
Finisher SR730	95
Replacing the Toner Bottle.....	97

6. Making Printer Settings with the Control Panel

Menu Chart	99
Accessing the Main Menu	102
Paper Input Menu	104
Paper Input Parameters	104
Changing the Paper Input Menu	106
List/Test Print Menu	108
List/Test Print Parameters.....	108
Printing a Configuration Page	108
Interpreting the Configuration Page	110
Maintenance Menu	112
Maintenance Menu Parameters	112
Changing the Maintenance Menu	113
System Menu	116
System Parameters.....	116
Changing the System Menu	120
Host Interface Menu	122
Host Interface Parameters	122
Changing the Host Interface Menu	125
PCL Menu	127
PCL Parameters.....	127
Changing the PCL Menu.....	128
Language Menu	130
Changing the Language Menu	130

7. Appendix

Stapling Position and Punch Position	133
Spool Printing	135
Paper Size and Resolution	136
With Frame Priority	136
With Font Priority.....	137
Moving and Transporting the Printer	138
Moving the Printer	138
Specifications	140
Mainframe	140
Options.....	143
INDEX	148

1. Setting Up the Printer Driver and Canceling a Print Job

PCL 6/5e - Accessing the Printer Properties

Windows 95/98/Me - Accessing the Printer Properties

Changing the default printer settings

- 1** Click **[Start]** on the taskbar, point to **[Settings]**, and then click **[Printers]**.
The **[Printers]** window appears.
- 2** Click to select the icon of the printer whose default settings you want to change.
- 3** On the **[File]** menu, click **[Properties]**.
The Printer Properties appear.
- 4** Make any settings you require, and then click **[OK]**.

 **Note**

- With some applications, the printer driver's settings are not used, and the application's own default settings are applied.

Making printer settings from an application

To make the printer settings for a specific application, open the **[Printer Properties]** dialog box from that application. The following example describes how to make settings for the WordPad application that comes with Windows 95/98/Me.

 **Note**

- The actual procedure you should follow to open the **[Printer Properties]** dialog box may differ depending on the application. For more information, see the documentation that comes with the application you are using.
- Any settings you make in the following procedure are valid for the current application only.

- 1** On the **[File]** menu, click **[Print]**.
The **[Print]** dialog box appears.
- 2** Select the printer you want to use in the **[Name]** list box, and then click **[Properties]**.
The Printer Properties appear.
- 3** Make any settings you require, and then click **[OK]**.
- 4** Click **[OK]** to start printing.

Windows 2000 - Accessing the Printer Properties

1

Changing the default printer settings - Printer Properties

 **Limitation**

- Changing the setting of the printer requires Manage Printers permission. Members of the Administrators and Power Users groups have Manage Printers permission by default. When you set up options, log on using an account that has Manage Printers permission.

1 Click **[Start]** on the taskbar, point to **[Settings]**, and then click **[Printers]**.

The **[Printers]** window appears.

2 Click to select the icon of the printer whose default setting you want to change.

3 On the **[File]** menu, click **[Properties]**.

The Printer Properties appear.

4 Make any settings you require, and then click **[OK]**.

 **Note**

- Settings you make here are used as the default settings for all applications.

Changing the default printer settings – Printing Preferences Properties

 **Limitation**

- Changing the setting of the printer requires Manage Printers permission. Members of the Administrators and Power Users groups have Manage Printers permission by default. When you set up options, log on using an account that has Manage Printers permission.

1 Click **[Start]** on the taskbar, point to **[Settings]**, and then click **[Printers]**.

The **[Printers]** window appears.

2 Click to select the icon of the printer whose default settings you want to change.

3 On the **[File]** menu, click **[Printing Preferences...]**.

The Printing Preferences Properties appear.

4 Make any settings you require, and then click **[OK]**.

 **Note**

- Settings you make here are used as the default settings for all applications.

Making printer settings from an application

To make the printer settings for a specific application, open the **[Print]** dialog box from that application. The following example describes how to make settings for the WordPad application that comes with Windows 2000.

Note

- The actual procedures you should follow to open the **[Print]** dialog box may differ depending on the application. For more information, see the documentation that comes with the application you are using.
- Any settings you make in the following procedure are valid for the current application only.

1 On the **[File]** menu, click **[Print...]**.

The **[Print]** dialog box appears.

2 Select the printer you want to use in the **[Select Printer]** box.

3 Make any settings you require, and then click **[Apply]** to start printing.

Windows NT 4.0 - Accessing the Printer Properties

Changing the default printer settings - Printer Properties

Limitation

- Changing the setting of the printer requires Full Control permission. Members of Administrators, Server Operators, Print Operators, and Power Users groups have Full Control permission by default. When you set up options, log on using an account that has Full Control permission.

1 Click **[Start]** on the taskbar, point to **[Settings]**, and then click **[Printers]**.

The **[Printers]** window appears.

2 Click to select the icon of the printer whose default settings you want to change.

3 On the **[File]** menu, click **[Properties]**.

The Printer Properties appear.

4 Make any settings you require, and then click **[OK]**.

Note

- Settings you make here are used as the default settings for all applications.

Changing the default printer settings – Default Document Properties

Limitation

- Changing the setting of the printer requires Full Control permission. Members of the Administrators, Server Operators, Print Operators, and Power Users groups have Full Control permission by default. When you set up options, log on using an account that has Full Control permission.

1 Click **[Start]** on the taskbar, point to **[Settings]**, and then click **[Printers]**.

The **[Printers]** window appears.

2 Click to select the icon of the printer whose default settings you want to change.

3 On the **[File]** menu, click **[Document Defaults]**.

The Default Document Properties appear.

4 Make any settings you require, and then click **[OK]**.

Note

- Settings you make here are used as the default settings for all applications.

Making printer settings from an application

To make the printer settings for a specific application, open the **[Printer Properties]** dialog box from that application. The following example describes how to make settings for the WordPad application that comes with Windows NT 4.0.

Note

- The actual procedure you should follow to open the **[Printer Properties]** dialog box may differ depending on the application. For more information, see the documentation that comes with the application you are using.
- Any settings you make in the following procedure are valid for the current application only.

1 On the **[File]** menu, click **[Print]**.

The **[Print]** dialog box appears.

2 Select the printer you want to use in the **[Name]** list box, and then click **[Properties]**.

The Printer Properties appear.

3 Make any settings you require, and then click **[OK]**.

4 Click **[OK]** to start printing.

RPCS - Accessing the Printer Properties

Windows 95/98/Me - Accessing the Printer Properties

1

Changing the default printer settings

- 1** Click **[Start]** on the taskbar, point to **[Settings]**, and then click **[Printers]**.

The **[Printers]** window appears.

- 2** Click to select the icon of the printer whose default settings you want to change.

- 3** On the **[File]** menu, click **[Properties]**.

The Printer Properties appear.

- 4** Make any settings you require, and then click **[OK]**.

 **Note**

- With some applications, the printer driver's settings are not used, and the application's own default settings are applied.

Making printer settings from an application

To make the printer settings for a specific application, open the **[Printer Properties]** dialog box from that application. The following example describes how to make settings for the WordPad application that comes with Windows 95/98/Me.

 **Note**

- The actual procedure you should follow to open the **[Printer Properties]** dialog box may differ depending on the application. For more information, see the documentation that comes with the application you are using.
- Any settings you make in the following procedure are valid for the current application only.

- 1** On the **[File]** menu, click **[Print]**.

The **[Print]** dialog box appears.

- 2** Select the printer you want to use in the **[Name]** list box, and then click **[Properties]**.

The Printer Properties appear.

- 3** Make any settings you require, and then click **[OK]**.

- 4** Click **[OK]** to start printing.

Windows 2000 - Accessing the Printer Properties

1

Changing the default printer settings - Printer Properties

 **Limitation**

- Changing the setting of the printer requires Manage Printers permission. Members of the Administrators and Power Users groups have Manage Printers permission by default. When you set up options, log on using an account that has Manage Printers permission.

1 Click **[Start]** on the taskbar, point to **[Settings]**, and then click **[Printers]**.

The **[Printers]** window appears.

2 Click to select the icon of the printer whose default settings you want to change.

3 On the **[File]** menu, click **[Properties]**.

The Printer Properties appear.

4 Make any settings you require, and then click **[OK]**.

 **Note**

- Settings you make here are used as the default settings for all applications.

Changing the default printer settings – Printing Preferences Properties

 **Limitation**

- Changing the setting of the printer requires Manage Printers permission. Members of the Administrators and Power Users groups have Manage Printers permission by default. When you set up options, log on using an account that has Manage Printers permission.

1 Click **[Start]** on the taskbar, point to **[Settings]**, and then click **[Printers]**.

The **[Printers]** window appears.

2 Click to select the icon of the printer whose default settings you want to change.

3 On the **[File]** menu, click **[Printing Preferences...]**.

The Printing Preferences Properties appear.

4 Make any settings you require, and then click **[OK]**.

 **Note**

- Settings you make here are used as the default settings for all applications.

Making printer settings from an application

To make the printer settings for a specific application, open the **[Print]** dialog box from that application. The following example describes how to make settings for the WordPad application that comes with Windows 2000.

Note

- The actual procedures you should follow to open the **[Print]** dialog box may differ depending on the application. For more information, see the documentation that comes with the application you are using.
- Any settings you make in the following procedure are valid for the current application only.

1 On the **[File]** menu, click **[Print...]**.

The **[Print]** dialog box appears.

2 Select the printer you want to use in the **[Select Printer]** box.

3 Make any settings you require, and then click **[Apply]** to start printing.

Windows NT 4.0 - Accessing the Printer Properties

Changing the default printer settings - Printer Properties

Limitation

- Changing the setting of the printer requires Full Control permission. Members of Administrators, Server Operators, Print Operators, and Power Users groups have Full Control permission by default. When you set up options, log on using an account that has Full Control permission.

1 Click **[Start]** on the taskbar, point to **[Settings]**, and then click **[Printers]**.

The **[Printers]** window appears.

2 Click to select the icon of the printer you want to use.

3 On the **[File]** menu, click **[Properties]**.

The Printer Properties appear.

4 Make any settings you require, and then click **[OK]**.

Note

- Settings you make here are used as the default settings for all applications.

Changing the default printer settings – Default Document Properties

Limitation

- Changing the setting of the printer requires Full Control permission. Members of the Administrators, Server Operators, Print Operators, and Power Users groups have Full Control permission by default. When you set up options, log on using an account that has Full Control permission.

1 Click **[Start]** on the taskbar, point to **[Settings]**, and then click **[Printers]**.

The **[Printers]** window appears.

2 Click to select the icon of the printer you want to use.

3 On the **[File]** menu, click **[Document Defaults]**.

The Default Document Properties appear.

4 Make any settings you require, and then click **[OK]**.

Note

- Settings you make here are used as the default settings for all applications.

Making printer settings from an application

To make the printer settings for a specific application, open the **[Printer Properties]** dialog box from that application. The following example describes how to make settings for the WordPad application that comes with Windows NT 4.0.

Note

- The actual procedure you should follow to open the **[Printer Properties]** dialog box may differ depending on the application. For more information, see the documentation that comes with the application you are using.
- Any settings you make in the following procedure are valid for the current application only.

1 On the **[File]** menu, click **[Print]**.

The **[Print]** dialog box appears.

2 Select the printer you want to use in the **[Name]** list box, and then click **[Properties]**.

The Printer Properties appear.

3 Make any settings you require, and then click **[OK]**.

4 Click **[OK]** to start printing.

PostScript - Setting Up for Printing

Windows 95/98/Me - Accessing the Printer Properties

1

Changing the default printer settings

- 1** Click **[Start]** on the taskbar, point to **[Settings]**, and then click **[Printers]**.

The **[Printers]** window appears.

- 2** Click to select the icon of the printer whose default settings you want to change.

- 3** On the **[File]** menu, click **[Properties]**.

The Printer Properties appear.

- 4** Make any settings you require, and then click **[OK]**.

- 5** Click **[OK]**.

 **Note**

- With some applications, the printer driver's settings are not used, and the application's own default settings are applied.

Making printer settings from an application

To make the printer settings for a specific application, open the **[Printer Properties]** dialog box from that application. The following example describes how to make settings for the WordPad application that comes with Windows 95/98/Me.

 **Note**

- The actual procedure you should follow to open the **[Printer Properties]** dialog box may differ depending on the application. For more information, see the documentation that comes with the application you are using.
- Any settings you make in the following procedure are valid for the current application only.

- 1** On the **[File]** menu, click **[Print]**.

The **[Print]** dialog box appears.

- 2** Select the printer you want to use in the **[Name]** list box, and then click **[Properties]**.

The Printer Properties appear.

- 3** Make any settings you require, and then click **[OK]**.

- 4** Click **[OK]** to start printing.

Windows 2000 - Accessing the Printer Properties

1

Changing the default printer settings - Printer Properties

Limitation

- Changing the setting of the printer requires Manage Printers permission. Members of the Administrators and Power Users groups have Manage Printers permission by default. When you set up options, log on using an account that has Manage Printers permission.

1 Click **[Start]** on the taskbar, point to **[Settings]**, and then click **[Printers]**.

The **[Printers]** window appears.

2 Click to select the icon of the printer whose default settings you want to change.

3 On the **[File]** menu, click **[Properties]**.

The Printer Properties appear.

4 Make any settings you require, and then click **[OK]**.

Note

- Settings you make here are used as the default settings for all applications.

Changing the default printer settings – Printing Preferences Properties

Limitation

- Changing the setting of the printer requires Manage Printers permission. Members of the Administrators and Power Users groups have Manage Printers permission by default. When you set up options, log on using an account that has Manage Printers permission.

1 Click **[Start]** on the taskbar, point to **[Settings]**, and then click **[Printers]**.

The **[Printers]** window appears.

2 Click to select the icon of the printer whose default settings you want to change.

3 On the **[File]** menu, click **[Printing Preferences...]**.

The Printing Preferences Properties appear.

4 Make any settings you require, and then click **[OK]**.

Note

- Settings you make here are used as the default settings for all applications.

Making printer settings from an application

To make the printer settings for a specific application, open the **[Print]** dialog box from that application. The following example describes how to make settings for the WordPad application that comes with Windows 2000.

Note

- The actual procedures you should follow to open the **[Print]** dialog box may differ depending on the application. For more information, see the documentation that comes with the application you are using.
- Any settings you make in the following procedure are valid for the current application only.

1 On the **[File]** menu, click **[Print...]**.

The **[Print]** dialog box appears.

2 Select the printer you want to use in the **[Select Printer]** box.

3 Make any settings you require, and then click **[Print]** to start printing.

4 Click **[OK]** to start printing.

Windows NT 4.0 - Accessing the Printer Properties

Changing the default printer settings - Printer Properties

Limitation

- Changing the setting of the printer requires Full Control permission. Members of Administrators, Server Operators, Print Operators, and Power Users groups have Full Control permission by default. When you set up options, log on using an account that has Full Control permission.

1 Click **[Start]** on the taskbar, point to **[Settings]**, and then click **[Printers]**.

The **[Printers]** window appears .

2 Click to select the icon of the printer whose default settings you want to change.

3 On the **[File]** menu, click **[Properties]**.

The Printer Properties appear.

4 Make any settings you require, and then click **[OK]**.

Note

- Setting you make here are used as the default settings for all applications.

Changing the default printer settings - Default Document Properties

Limitation

- Changing the setting of the printer requires Full Control permission. Members of the Administrators, Server Operators, Print Operators, and Power Users groups have Full Control permission by default. When you set up options, log on using an account that has Full Control permission.

1 Click **[Start]** on the taskbar, point to **[Settings]**, and then click **[Printers]**.

The **[Printers]** window appears.

2 Click to select the icon of the printer you want to use.

3 On the **[File]** menu, click **[Document Defaults]**.

The Default Document Properties appear.

4 Make any settings you require, and then click **[OK]**.

Note

- Settings you make here are used as the default settings for all applications.

Making printer settings from an application

To make the printer settings for a specific application, open the **[Printer Properties]** dialog box from that application. The following example describes how to make settings for the WordPad application that comes with Windows NT 4.0.

Note

- The actual procedure you should follow to open the **[Printer Properties]** dialog box may differ depending on the application. For more information, see the documentation that comes with the application you are using.
- Any settings you make in the following procedure are valid for the current application only.

1 On the **[File]** menu, click **[Print]**.

The **[Print]** dialog box appears.

2 Select the printer you want to use in the **[Name]** list box, and then click **[Properties]**.

The Printer Properties appear.

3 Make any settings you require, and then click **[OK]**.

4 Click **[OK]** to start printing.

Macintosh - Setting Up for Printing

Making paper settings from an application

- 1** Open the file you want to print.
- 2** On the [File] menu, click [Page Setup].
The [AdobePS Page Setup] dialog box appears.
- 3** Confirm that the printer you want to use is shown in the [Format for:] box.

 **Note**

- If the printer is not shown in the [Format for:] box, use the pop-up menu to display a list of available printers.

 **Reference**

The actual appearance of the page setup depends on the application you are using. See the documentation that comes with the Macintosh for more information.

- 4** From the [Paper:] box, select the paper size.
- 5** Make any settings you require, and then click [OK].

Setting up for printing from an application

- 1** Open the file you want to print.
- 2** On the [File] menu, click [Print].
The Printer Settings appear.
- 3** Confirm that the printer is selected in the [Printer :] box.
- 4** Make any settings you require, and then click [Print] to start printing.

Canceling a Print Job

1

Windows 95/98/Me - Canceling a Print Job

1 Double-click the printer icon on the Windows taskbar.

A window appears, showing all the print jobs that are currently queuing to be printed. Check the current status of the job you want to cancel.

2 Select the name of the job you want to cancel.

3 On the [Document] menu, click [Cancel Printing].

 **Note**

You can also open the print job queue window by double-clicking the printer icon in the [Printer] window.

4 Press [Job Reset] on the control panel.

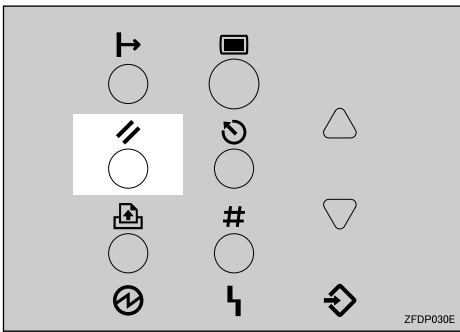

The message appears on the panel display indicating that the print job is being canceled.

 **Important**

This procedure cancels the print job that is being processed by the printer. In some cases, the printer may already be processing data for the next print job following the one currently being output. In this case, the next print job is also canceled when you press [Job Reset].

When the printer is being shared by multiple computers, be careful not to accidentally cancel someone else's print job.

 **Note**

You cannot stop printing data that has already been processed internally by the printer. Because of this, printing may continue for a few pages after you press [Job Reset].

A print job that contains a large volume of data may take considerable time to stop.

Windows 2000 - Canceling a Print Job

1 Double-click the printer icon on the Windows taskbar.

A window appears, showing all the print jobs that are currently queuing to be printed. Check the current status of the job you want to cancel.

2 Select the name of the job you want to cancel.

3 On the [Document] menu, click [Cancel Printing].

Note

- You can also open the print job queue window by double-clicking the printer icon in the [Printers] window.

4 Press [Job Reset] on the control panel.

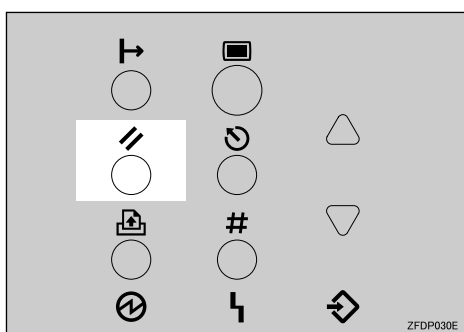

The message appears on the panel display indicating that the print job is being canceled.

Important

- This procedure cancels the print job that is being processed by the printer. In some cases, the printer may already be processing data for the next print job following the one currently being output. In this case, the next print job is also canceled when you press [Job Reset].
- When the printer is being shared by multiple computers, be careful not to accidentally cancel someone else's print job.

Note

- You cannot stop printing data that has already been processed internally by the printer. Because of this, printing might continue for a few pages after you press [Job Reset].
- A print job that contains a large volume of data might take considerable time to stop.

Windows NT 4.0 - Canceling a Print Job

1

1 Double-click the printer icon on the Windows taskbar.

A window appears, showing all the print jobs that are currently queuing to be printed. Check the current status of the job you want to cancel.

2 Select the name of the job you want to cancel.

3 On the [Document] menu, click [Cancel Printing].

 **Note**

You can also open the print job queue window by double-clicking the printer icon in the [Printer] window.

4 Press [Job Reset] on the control panel.

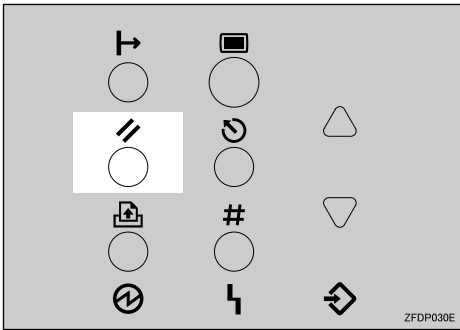

The message appears on the panel display indicating that the print job is being canceled.

 **Important**

- The procedure cancels the print job that is being processed by the printer. In some cases, the printer may already be processing data for the next print job following the one currently being output. In this case, the next print job is also canceled when you press [Job Reset].
- When the printer is being shared by multiple computers, be careful not to accidentally cancel someone else's print job.

 **Note**

- You cannot stop printing data that has already been processed internally by the printer. Because of this, printing may continue for a few pages after you press [Job Reset].
- A print job that contains a large volume of data may take considerable time to stop.

Macintosh - Canceling a Print Job

1 Double-click the printer's icon on the desktop.

A window appears, showing all the print jobs that are currently queuing to be printed. Check the current status of the job you want to cancel.

2 Select the name of the job you want to cancel.

3 Click the pause icon, and then click the trash icon,

4 Press **[Job Reset]** on the control panel.

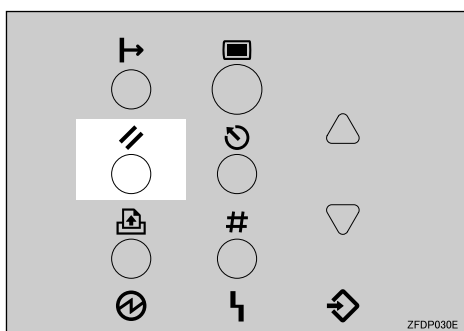

The message appears on the panel display indicating that the print job is being canceled.

Important

- This procedure cancels the print job that is being processed by the printer. In some case, the printer may already be processing data for the next print job following the one currently being output. In this case, the next print job is also canceled when you press **[Job Reset]**.
- When the printer is being shared by multiple computers, be careful not to accidentally cancel someone else's print job.

Note

- You cannot stop printing data that has already been processed internally by the printer. Because of this, printing may continue for a few pages after you press **[Job Reset]**.
- A print job that contains a large volume of data may take considerable time to stop.

2. Uninstalling the Printer Driver and Software

Uninstalling the PCL 6/5e Printer Driver

This section describes how to uninstall the printer driver. The actual procedure may differ depending on the operating system.

Follow one of the appropriate procedures below.

Windows 95/98/Me - Uninstalling the PCL 6/5e Printer Driver

- 1** Close all the applications that are running.
- 2** Click **[Start]** on the taskbar, point to **[Settings]**, and then click **[Printers]**.
The **[Printers]** window appears.
- 3** Click to select the icon of the printer you want to remove.
- 4** On the **[File]** menu, click **[Delete]**.
A confirmation dialog box appears.
- 5** Click **[Yes]** to uninstall the printer driver.

Windows 2000 - Uninstalling the PCL 6/5e Printer Driver

Limitation

- Uninstalling a printer driver requires Manage Printers permission. Members of the Administrators and Power Users groups have Manage Printers permission by default. When you uninstall a printer driver, log on using an account that has Manage Printers permission.

- 1** Close all the applications that are running.
- 2** Click **[Start]** on the taskbar, point to **[Settings]**, and then click **[Printers]**.
The **[Printers]** window appears.
- 3** Click to select the icon of the printer you want to remove.
- 4** On the **[File]** menu, click **[Delete]**.
A confirmation dialog box appears.
- 5** Click **[Yes]** to uninstall the printer driver.

Windows NT 4.0 - Uninstalling the PCL 6/5e Printer Driver

! Limitation

- Uninstalling a printer driver requires Full Control permission. Members of the Administrators, Server Operators, Print Operators, and Power Users groups have Full Control Permission by default. When you install a printer driver, log on using an account that has Full Control permission.

1 Close all applications that are running.

2 Click **[Start]** on the taskbar, point to **[Settings]**, and then click **[Printers]**.

The **[Printers]** window appears.

3 Click to select the icon of the printer you want to remove.

4 On the **[File]** menu, click **[Delete]**.

A confirmation dialog box appears.

5 Click **[Yes]** to uninstall the printer driver.

Uninstalling the RPCS Printer Driver

This section describes how to uninstall the printer driver. The actual procedure may differ depending on the operating system.

Follow one of the appropriate procedures below.

Windows 95/98/Me - Uninstalling the RPCS Printer Driver

2

- 1** Close all the applications that are running.
- 2** Click [Start] on the taskbar, point to [Settings], and then click [Printers].
The [Printers] window appears.
- 3** Click to select the icon of the printer you want to remove.
- 4** On the [File] menu, click [Delete].
A confirmation dialog box appears.
- 5** Click [Yes] to uninstall the printer driver.

Windows 2000 - Uninstalling the RPCS Printer Driver

Limitation

- Uninstalling a printer driver requires Manage Printers permission. Members of the Administrators and Power Users groups have Manage Printers permission by default. When you uninstall a printer driver, log on using an account that has Manage Printers permission.

- 1** Close all the applications that are running.
- 2** Click [Start] on the taskbar, point to [Settings], and then click [Printers].
The [Printers] window appears.
- 3** Click to select the icon of the printer you want to remove.
- 4** On the [File] menu, click [Delete].
A confirmation dialog box appears.
- 5** Click [Yes] to uninstall the printer driver.

Windows NT 4.0 - Uninstalling the RPCS Printer Driver

! Limitation

- ❑ Uninstalling a printer driver requires Full Control permission. Members of the Administrators, Server Operators, Print Operators, and Power Users groups have Full Control Permission by default. When you install a printer driver, log on using an account that has Full Control permission.

1 Close all applications that are running.

2 Click [Start] on the taskbar, point to [Settings], and then click [Printers].

The [Printers] window appears.

3 Click to select the icon of the printer you want to remove.

4 On the [File] menu, click [Delete].

A confirmation dialog box appears.

5 Click [Yes] to uninstall the printer driver.

Uninstalling the PostScript Printer Driver

This section describes how to uninstall the PostScript printer driver. The actual procedure may differ depending on the operating system. Follow one of the appropriate procedures below.

Windows 95/98/Me - Uninstalling the PostScript Printer Driver

2

- 1** Close all applications that are running.
- 2** Click **[Start]** on the taskbar, point to **[Settings]**, and then click **[Printers]**.
The **[Printers]** window appears.
- 3** Click to select the icon of the printer you want to remove.
- 4** On the **[File]** menu, click **[Delete]**.
A confirmation dialog box appears.
- 5** Click **[Yes]** to uninstall the printer driver.

Windows 2000 - Uninstalling the PostScript Printer Driver

Limitation

- Uninstalling a printer driver requires Manage Printers permission. Members of the Administrators and Power Users groups have Manage Printers permission by default. When you uninstall a printer driver, log on using an account that has Manage Printers permission.

- 1** Close all the applications that are running.
- 2** Click **[Start]** on the taskbar, point to **[Settings]**, and then click **[Printers]**.
The **[Printers]** window appears.
- 3** Click to select the icon of the printer you want to remove.
- 4** On the **[File]** menu, click **[Delete]**.
A confirmation dialog box appears.
- 5** Click **[Yes]** to uninstall the printer driver.

Windows NT 4.0 - Uninstalling the PostScript Printer Driver

! Limitation

- Uninstalling a printer driver requires Full Control permission. Members of the Administrators, Server Operators, Print Operators, and Power Users groups have Full Control Permission by default. When you uninstall a printer driver, log on using an account that has Full Control permission.

1 Close all applications that are running.

2 Click **[Start]** on the taskbar, point to **[Settings]**, and then click **[Printers]**.

The **[Printers]** window appears.

3 Click to select the icon of the printer you want to remove.

4 On the **[File]** menu, click **[Delete]**.

A confirmation dialog box appears.

5 Click **[Yes]** to uninstall the printer driver.

3. Paper and Other Media

Paper and Other Media Supported by This Printer

Paper Sizes

This section describes the type, size, feed direction, and maximum amount of paper that can be loaded into each paper tray in this printer.

Important

- If you use damp or curled paper, misfeeds might occur. In such a case, try turning over the paper stack in the paper tray. If there is no improvement, change to paper with less curl.
- Be sure to set the paper size dial to match the actual paper size loaded in the tray. When the actual paper size is not shown on the dial, set the dial to “✖” and select the paper size using the control panel.
- For tray 1, 2, 3 and 4, the dial setting overrides settings selected with the control panel.

Note

- The following conventions are used to describe paper feed direction:

Example on the panel display	Paper feed direction
A4 (210 × 297)	short-edge feed direction
A4 (297 × 210)	long-edge feed direction

- It is recommended that you load paper having the size and direction you frequently use in the tray selected with “Tray Priority”. For more information about Tray Priority, see p.104 “Paper Input Menu”.
- When loading paper having the same size in more than one tray, it is recommended that you load paper in the same direction.
- For more information about the meanings of symbols, see the notes at the bottom of each table.

Reference

For more information about loading each type of paper, see p.33 “Loading Paper and Other Media”.

◆ Input paper sizes and paper feed directions supported by each paper tray (Metric version)

	Feed Direction	Size (mm)	Standard Tray (tray1/tray2)	Paper Bank PS430 (tray3/tray4)	Large Capacity Tray RT36	Bypass Tray
A3	☐	297 × 420	○	○	X	★
B4 JIS	☐	257 × 364	★	★	X	★
A4	☐	210 × 297	○	○	X	★
	☐	297 × 210	○	○	○	★
B5 JIS	☐	182 × 257	★	★	X	★
	☐	257 × 182	★	★	X	★
A5	☐	148 × 210	○	○	X	★
	☐	210 × 148	X	X	X	★
A6	☐	105 × 148	X	X	X	★
11 × 17 inches	☐	279 × 432	★	★	X	★
Legal	☐	216 × 356	★	★	X	★
Letter	☐	216 × 279	○	○	X	★
	☐	279 × 216	○	○	○	★
5 1/2 × 8 1/2 inches	☐	140 × 216	★	★	X	★
Executive	☐	184 × 267	★	★	X	★
	☐	267 × 184	X	X	X	★
Folio	☐	210 × 330	★	★	X	★
Foolscap	☐	216 × 330	★	★	X	★
F/GL	☐	203 × 330	○	○	X	★
Com#10 Env (4 1/8 × 9 1/2 inches)	☐	104.8 × 241.3	X	X	X	★
C5 Env (6.38 × 9.02 inches)	☐	162 × 229	X	X	X	★
C6 Env (4.49 × 6.38 inches)	☐	114 × 162	X	X	X	★
DL Env (4.33 × 8.66 inches)	☐	110 × 220	X	X	X	★
Custom Size (PCL 6/PS only)	—	—	X	X	X	☆





















- means that the size is supported and indicated on the tray dial. Be sure to set the paper size dial to match the actual paper size loaded in the tray.



- ★ means that the size is supported but not indicated on the tray dial. Set the tray dial to “★”, and select the paper size using the control panel. (There is no dial for the Bypass Tray.)
- ☆ means that the size is supported but the paper size should be set with the control panel as a custom size. The supported size is approximately 100 - 297 mm in width and 148 - 432 mm in length. The supported size may differ depending on the printer language you use.
- X means that the size is not supported.

Important

- If you want to load letter  size paper into the Large Capacity Tray RT36, contact your sales or service representative.

◆ Input paper sizes and paper feed directions supported by each paper tray (Inch version)

	Feed Direction	Size (inch)	Standard Tray (tray1/tray2)	Paper Bank PS430 (tray3/tray4)	Large Capacity Tray RT36	Bypass Tray
11 × 17 inches		11 × 17	○	○	X	★
Legal		8 ¹ / ₂ × 14	○	○	X	★
Letter		8 ¹ / ₂ × 11	○	○	X	★
		11 × 8 ¹ / ₂	○	○	○	★
5 ¹ / ₂ × 8 ¹ / ₂ inches		5 ¹ / ₂ × 8 ¹ / ₂	★	★	X	★
Executive		7 ¹ / ₄ × 10 ¹ / ₂	★	★	X	★
		10 ¹ / ₂ × 7 ¹ / ₄	X	X	X	★
A3		11.69 × 16.54	★	★	X	★
B4 JIS		10.12 × 14.33	★	★	X	★
A4		8.27 × 11.69	○	○	X	★
		11.69 × 8.27	○	○	○	★
B5 JIS		7.17 × 10.12	★	★	X	★
		10.12 × 7.17	★	★	X	★
A5		5.83 × 8.27	★	★	X	★
		8.27 × 5.83	X	X	X	★
A6		4.13 × 5.83	X	X	X	★
Folio		8 ¹ / ₄ × 13	★	★	X	★
Foolscap		8 ¹ / ₂ × 13	○	○	X	★
F/GL		8 × 13	★	★	X	★
Com#10 Env		4 ¹ / ₈ × 9 ¹ / ₂	X	X	X	★

	Feed Direction	Size (inch)	Standard Tray (tray1/tray2)	Paper Bank PS430 (tray3/tray4)	Large Capacity Tray RT36	Bypass Tray
C5 Env		6.38 × 9.02	X	X	X	★
C6 Env		4.49 × 6.38	X	X	X	★
DL Env		4.33 × 8.66	X	X	X	★
Custom Size (PCL 6/PS only)	—	—	X	X	X	☆

- ○ means that the size is supported and indicated on the tray dial. Be sure to set the paper size dial to match the actual paper size loaded in the tray.
- ★ means that the size is supported but not indicated on the tray dial. Set the tray dial to “✳”, and select the paper size using the control panel. (There is no dial for the Bypass Tray.)
- ☆ means that the size is supported but the paper size should be set with the control panel as a custom size. The supported size is approximately 3.9 - 11.7 inches in width and 5.8 - 17 inches in length. The supported size may differ depending on the printer language you use.
- X means that the size is not supported.

 **Important**

- If you want to load A4  size paper into the Large Capacity Tray RT36, contact your sales or service representative.

❖ Paper weight and number of sheets to be set

	Supported paper weight	Maximum number of sheets (plain paper) *1
Bypass Tray	52 - 163 g/m ² (16 - 43 lb. bond)	50 (80 g/m ² , 20 lb. bond) For other kind of papers, see p.29 “Types of Paper and Other Media”.
Standard Tray (Tray 1/2)	64 - 105 g/m ² (20 - 28 lb. bond)	500 (80 g/m ² , 20 lb. bond) × 2
Paper Bank PS430 (option)	64 - 105 g/m ² (20 - 28 lb. bond)	500 (80 g/m ² , 20 lb. bond) × 2
Large Capacity Tray RT36 (option)	64 - 105 g/m ² (20 - 28 lb. bond)	1,500 (80 g/m ² , 20 lb. bond)

*1 Confirm that the top of the stack is not higher than the limit mark inside the tray.

Paper Recommendations

Loading Paper

Important

- Do not use paper that is meant for an ink-jet printer, or it may stick to the fusing unit and cause a paper misfeed.
- When printing on an OHP transparency that has a print side, be sure to print on the print side. Otherwise, it may stick to the fusing unit and cause a paper misfeed.
- Set the paper as described below:
 - Standard Tray/Optional Paper Bank: Print side facing up
 - Large Capacity Tray: Print side facing down
 - Bypass Tray: Print side facing down
- Print quality cannot be guaranteed if paper other than the ones recommended is used. For more information about recommended paper, contact your sales or service representative.
- Do not use paper that has already been printed on by other printers.

Storing Paper

- Paper should always be stored properly. Improperly stored paper might result in poor print quality, paper misfeeds, or printer damage. Recommendations are as follows:
 - Avoid storing paper in humid areas.
 - Avoid exposing paper to direct sunlight.
 - Store on a flat surface.
- Keep paper in the package in which the paper came.

Types of Paper and Other Media

❖ Plain Paper

- Plain paper here means paper up to 105 g/m² (28 lb. bond).
- Any input tray can be used.
- A standard tray can hold up to 500 sheets per tray and 1000 sheets in total. The optional Paper Bank can hold up to 500 sheets per tray and 1000 sheets in total.
The Large Capacity Tray can hold up to 1,500 sheets.
The Bypass Tray can hold up to 50 sheets.
Confirm that the top of the stack is not higher than the limit mark inside the tray.

- The Bypass Tray supports custom size paper approximately 100 to 297 mm (3.9 to 11.7 inches) in width, and approximately 148 to 432 mm (5.8 to 17 inches) in length.

❖ **Thick Paper**

- Thick paper here means paper between 106 g/m² (28 lb. bond) to 163 g/m² (43 lb. bond).
- Use the Bypass Tray. Other input trays cannot be used.
- The Bypass Tray can hold paper up to 163 g/m² (43 lb. bond) in weight. The print quality is not guaranteed for paper thicker than this.
- Confirm that the top of the stack is not higher than the limit mark inside the tray.
- When printing on thick paper, select the thick paper mode with the control panel or the printer driver.

❖ **OHP transparencies**

- Use the Bypass Tray. Other trays cannot be used.
- Separate stuck OHP transparencies each time before printing.
- If OHP transparencies stick together when they feed, set them on the tray one by one or select "Slip sheet" in the printer driver. For more information about using "Slip sheet", see the printer driver's Help file.
- Confirm that the top of the stack is not higher than the limit mark inside the tray.
- When printing on OHP transparencies, select the OHP transparency mode with the control panel or the printer driver.
- Remove OHP transparencies from the tray after use to prevent them from sticking to each other.

❖ **Envelopes**

- Use the Bypass Tray. Other trays cannot be used.
- Load envelopes in the Bypass Tray with the print side down, the flaps closed and the sides in the feeding direction.

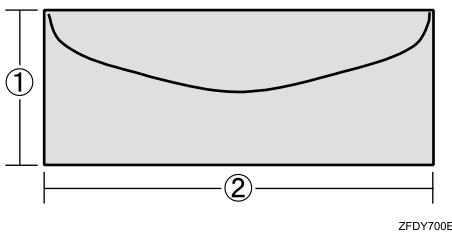

① : Must be 100 mm (3.9 inches) or longer.

② : Must be 148 mm (5.8 inches) or longer.

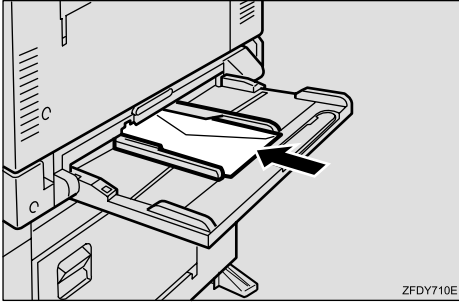

- Load only one size and type of envelope at a time.
- Do not forcibly push envelopes when loading.
- Confirm that the top of the stack is not higher than the limit mark inside the tray.
- Use flat envelopes with no curl. If they have a curl, flatten them.
- Use completely flat envelopes that contain no air inside.
- Do not print on both sides of envelopes.
- Do not use the following envelopes:
 - Envelopes with multiple flaps
 - Envelopes with a peel-off adhesive strip
 - Envelopes with windows or clasps
 - Envelopes made of paper that is not supported by this printer (See p.31 “Paper not supported by this printer”)
 - Envelopes with a large flap (Envelopes with a flap length longer than half the length of the envelope side)
- We recommend setting the margins to at least 15 mm (0.6 inch) for all four directions.
- Envelopes are output to the standard output tray only.
- Envelopes may wrinkle or print quality may be poor depending on the characteristics of the envelope such as weight and stiffness.
- See p.25 “Paper Sizes” for the supported sizes of envelopes.

❖ Paper not supported by this printer

Avoid using the following paper.

- Paper meant for an ink-jet printer
- Bent, folded, or creased paper
- Curled or twisted paper
- Torn paper
- Wrinkled paper
- Damp paper
- Paper that is dry enough to emit static electricity
- Paper that has already been printed onto, except a preprinted letterhead
- Coated paper

- Special paper, such as thermal paper, aluminum foil, carbon paper and conductive paper
- Paper whose weight is heavier or lighter than the limitation.
- Paper with windows, holes, perforations, cutouts, or embossing
- Adhesive label paper on which glue or base paper is exposed
- Paper with clips or staples

Printable Area

3

The following shows the printable area for this printer. Be sure to set the print margins correctly by the application.

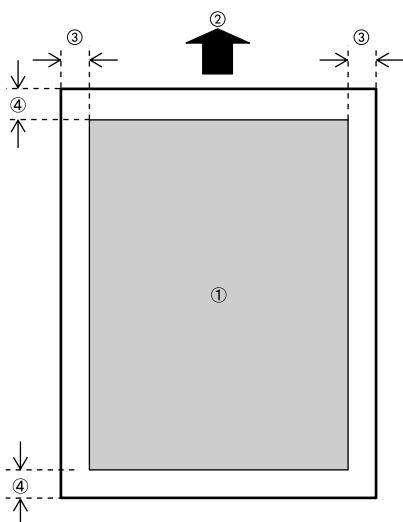

- ① : Printable area
- ② : Feed direction
- ③ : Approx. 2 mm (1/12 inch)
- ④ : Approx. 3 mm (1/8 inch)

 **Note**

- The printable area may vary depending on the paper size, printer language and printer driver settings.

Loading Paper and Other Media

Loading Paper in the Paper Tray

Loading Paper without Changing the Paper Size

This section describes instructions for loading paper whose size and feed direction is already set in the standard paper tray. If you want to change the paper size or feed direction, see p.34 "Changing Paper Size of the Paper Tray".

Reference

For more information on the size and feed direction of paper that can be loaded into the tray, see p.25 "Paper Sizes".

- 1** Slide the paper tray out until it stops.

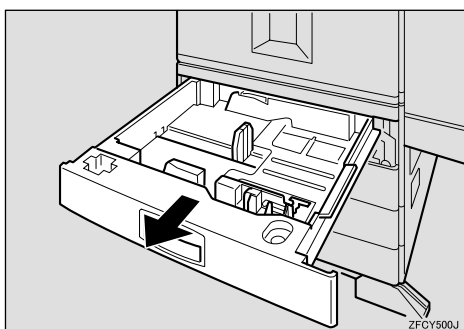

- 2** Remove the rear guide by pressing the sides of it.

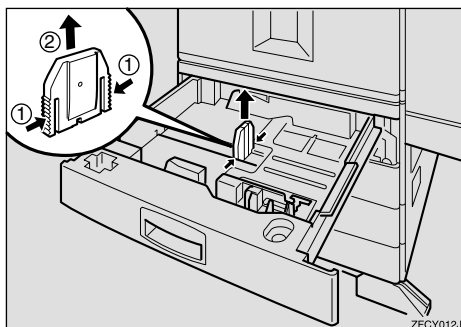

- 3** Align all four sides of the paper stack and load it into the tray with the print side up.

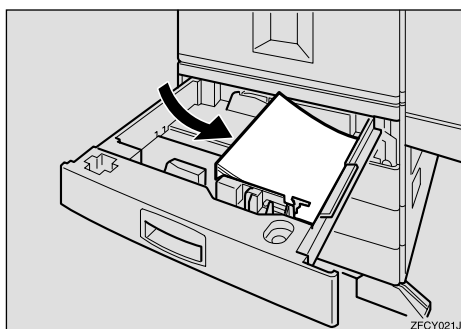

Important

- Confirm that the top of the stack is not higher than the limit mark inside the tray.

Note

- If there is space between the guides and the stack, move the guides to fit to the stack.

4 While lifting the left side of the paper, attach the rear guide.

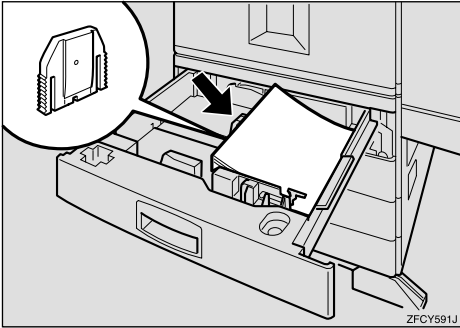

1 Slide the paper tray out until it stops.

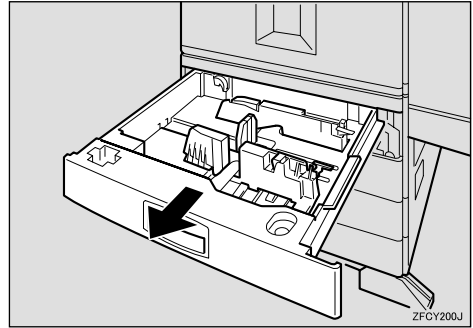

Note

- The rear guide is not necessary when 11 × 17 inch paper is loaded in the tray. Put it in the holder in the tray.

5 Slide the tray into the printer gently until it stops.

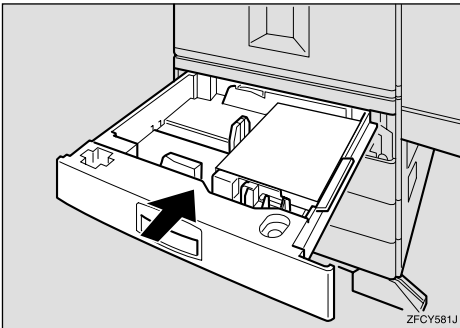

2 Remove the rear guide by pressing the sides of it.

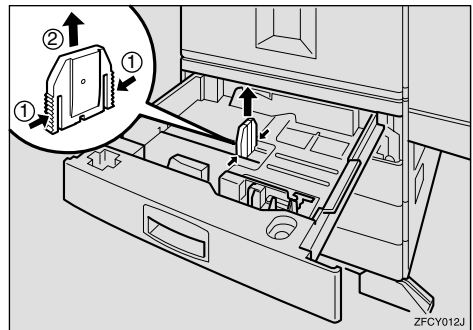

3 Release the lock for the side guides.

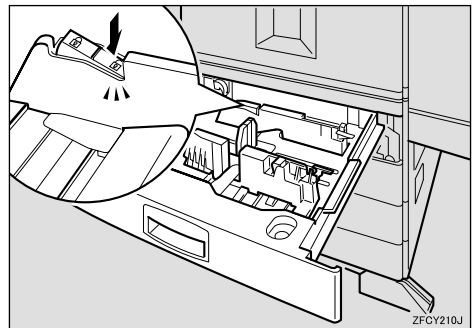

Changing Paper Size of the Paper Tray

Important

- Confirm that the setting of the paper size dial matches the size and feed direction of the paper in the tray. Otherwise, the printer might be damaged, or printing problems might occur.

- 4** While pressing the green lever of the side guides, move the side guides to widen the distance. Refer to the paper sizes on the bottom of the tray.

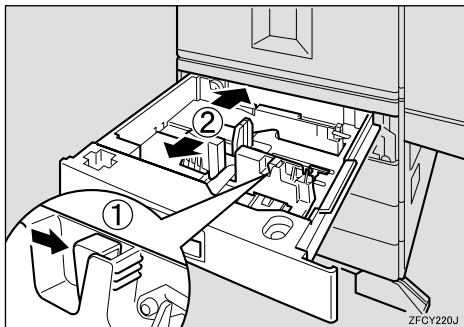

- 5** Align all four sides of the paper stack and load it into the tray with the print side up.

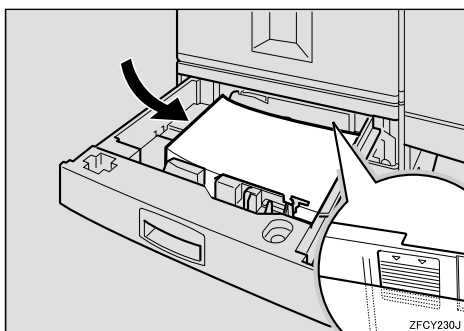

Important

- Confirm that the top of the stack is not higher than the limit mark inside the tray.

- 6** Adjust the side guides to the paper position while pressing the green lever.

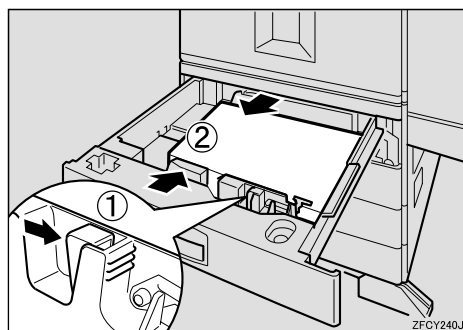

- 7** Lock the side guides.

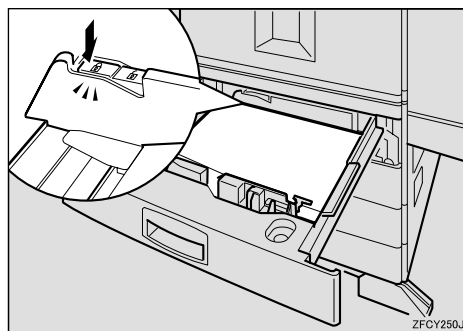

- 8** While lifting the left side of the paper, attach the rear guide.

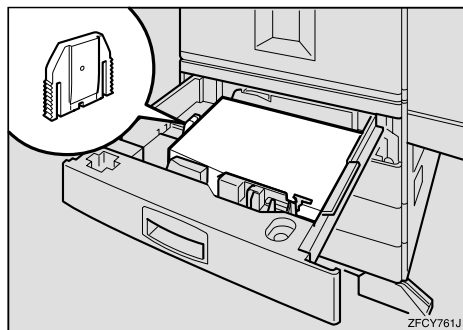



Note

- The rear guide is not necessary when 11 × 17 inch paper is loaded in the tray. Put it in the holder in the tray.

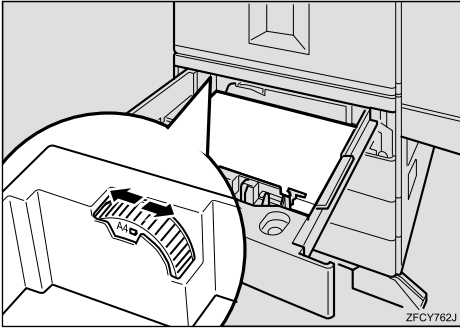
- 9 Adjust the paper size dial to match the size and feed direction of the paper in the paper tray.



Important

- A4, B5 and letter size paper can be loaded  and . Be sure to set the dial to the correct direction to avoid paper misfeeds.
- If you want to use a paper size and feed direction that are not indicated on the paper size dial, set the dial to "✱". In this case, you should specify the paper size using the control panel. ⇒ p.99 "Making Printer Settings with the Control Panel"

- 10 Slide the tray into the printer gently until it stops.

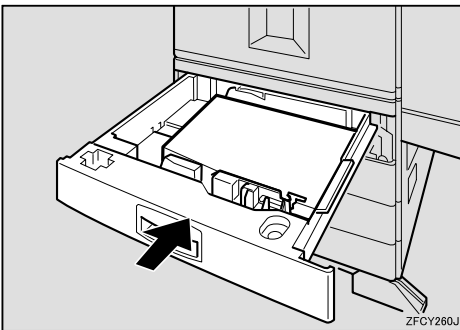

Note

- If the printer is in the Energy Saver mode when changing the paper size, Press **[Enter #]** before printing. This will update the size setting.

Loading Paper in the Optional Paper Bank

If you want to load paper without changing the size, see p.33 "Loading Paper in the Paper Tray".

Changing Paper Size of the Paper Tray

This section describes instructions for changing the paper size of the optional Paper Bank PS430.

Important

- Confirm that the setting of the paper size dial matches the size and feed direction of the paper in the tray. Otherwise, the printer might be damaged, or printing problem might occur.

Reference

For more information on the size and feed direction of paper that can be set in the tray, see p.25 "Paper Sizes".

- 1 Slide the paper tray out until it stops. First, lift it up slightly, and then pull it out.

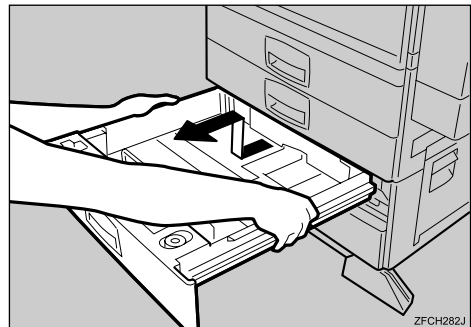

- 2** Remove the rear guide by pressing the sides of it.

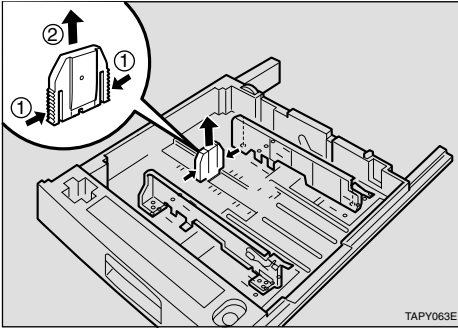

- 3** Pull the standard paper tray (Tray 1), and then take the screwdriver (1) from the tray.

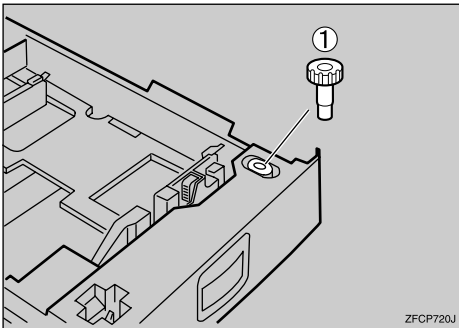

- 4** Remove the four screws inside of the tray using the screwdriver.

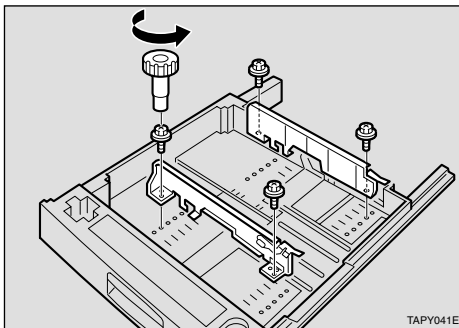

- 5** Re-position the side guides to match the paper size you want to load.

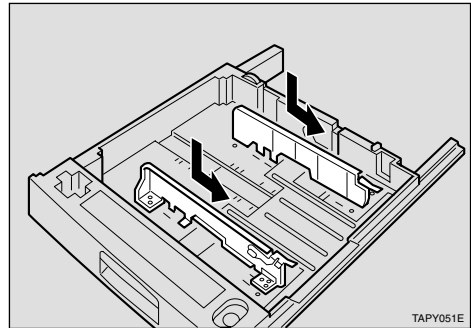

- 6** Lock the side guides with the four screws using the screwdriver.

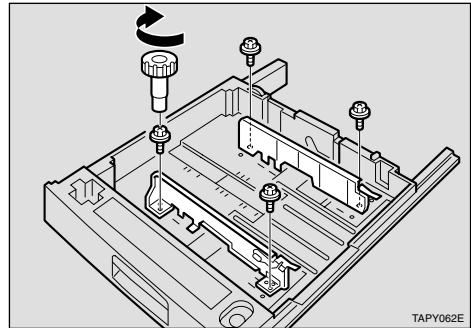

- 7** Align all four sides of the paper stack and load it into the tray with the print side up.

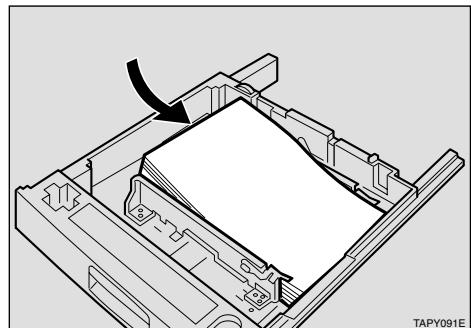

Important

- Confirm that the top of the stack is not higher than the limit mark inside the tray.

8 While lifting the left side of the paper, attach the rear guide.

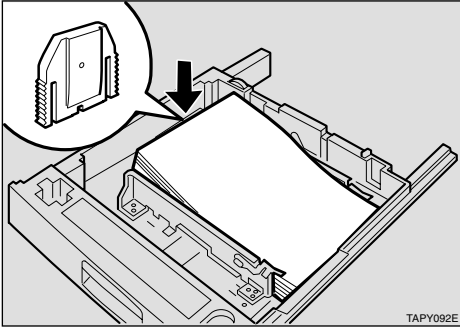

10 Slide the tray into the printer gently until it stops.

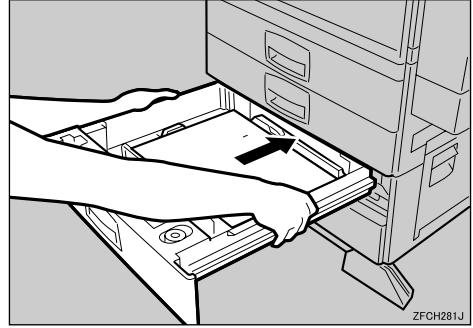

3

Note

- The rear guide is not necessary when 11 × 17 inch paper is loaded in the tray. Put it in the holder in the tray.

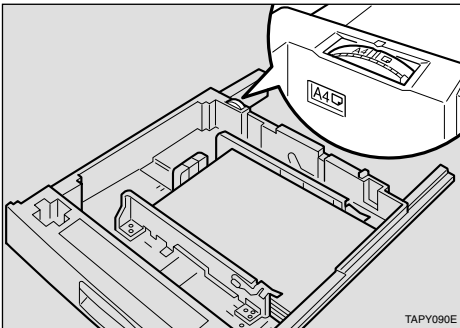

9 Adjust the paper size dial to match the size and feed direction of the paper in the paper tray.



Note

- If the printer is in the Energy Saver mode when changing the paper size, Press **[Enter #]** before printing. This will update the size setting.

Important

- A4, B5 and letter size paper can be loaded  and . Be sure to set the dial to the correct direction to avoid paper misfeeds.
- If you want to use a paper size and feed direction that are not indicated on the paper size dial, set the dial to "X". In this case, you should specify the paper size using the control panel. ⇒ p.99 "Making Printer Settings with the Control Panel"

Loading Paper in the Bypass Tray

Note

- ❑ Paper sizes supported by the Bypass Tray are approximately 100 - 297 mm (3.94 - 11.69 inches) in width, and approximately 148 - 432 mm (5.83 - 17 inches) in length.
- ❑ Specify a custom size with the control panel. For more information about using the control panel, see p.41 “Specifying a Custom Paper Size for the Bypass Tray”.
- ❑ If you load thick paper, OHP transparencies or envelopes, make the setting for each paper type with the control panel or the printer driver. See p.104 “Paper Input Menu”.
- ❑ The number of pages that can be loaded in the Bypass Tray differs depending on the paper type. Confirm that the top of the stack is not higher than the limit mark inside the tray.

Reference

For more information on the size and feed direction of paper that can be set in the tray, see p.25 “Paper Sizes”.

Limitation

- ❑ The following functions are not available with the Bypass Tray:
 - Duplex print
 - Limitless paper feed
 - Output from the Finisher (staple, punch)

1 Open the Bypass Tray.

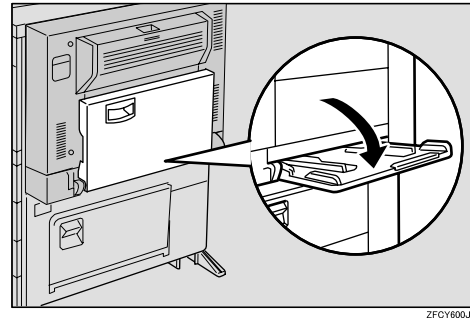

Note

- ❑ Swing out the extender (①) to support paper sizes larger than A4/letter ❑.

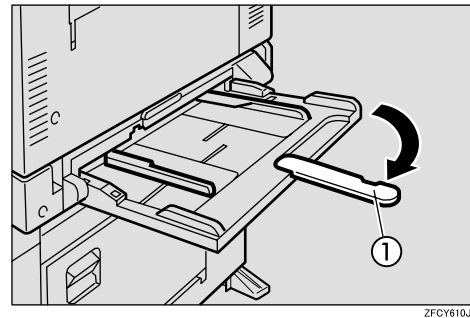

2 Slide the paper guides outwards, and then load paper until it stops with the print side down.

Important

- ❑ Confirm that the top of the stack is not higher than the limit mark inside the tray.
- ❑ Shuffle the paper before loading the stack onto the tray so multiple sheets are not fed in at one time.

- Adjust the paper guides to the paper width.

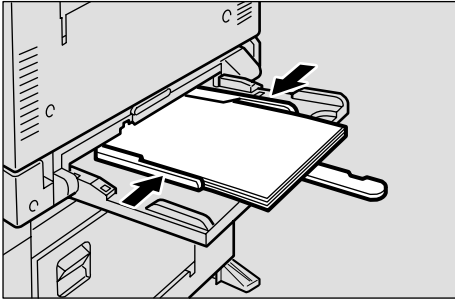

ZFCY620J

- Configure the tray for the loaded paper size and paper feed direction using the control panel.

Important

- The paper size selected with the printer driver overrides the one selected with the control panel. You do not have to make settings with the control panel if you have already made them with the printer driver.

Reference

For information about the printer driver, see the Help file.

For more information about configuring custom paper, see p.41 "Specifying a Custom Paper Size for the Bypass Tray".

- Press **[Menu]**.

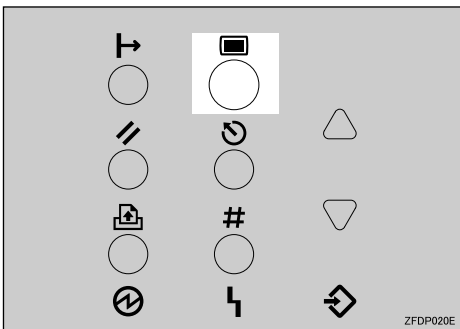

ZFDP020E

"Menu" appears on the panel display.

- Press **[▲]** or **[▼]** to display the "Paper Input" menu.



- Press **[Enter #]**.

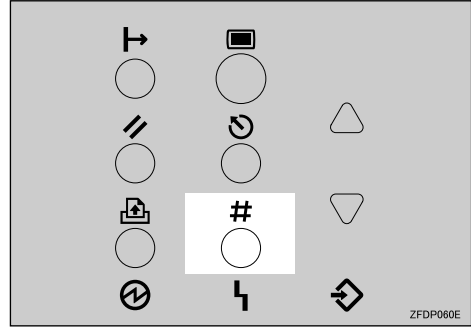

ZFDP080E

The following message appears on the panel display.

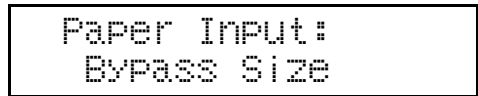

- Press **[Enter #]**.

The currently selected paper size appears on the panel display.

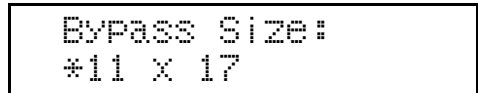

- Press **[▲]** or **[▼]** to select the paper size you want to use.
- Press **[Enter #]**. Wait for about two seconds.

- 7** After the panel display changes, press **[On Line]**.

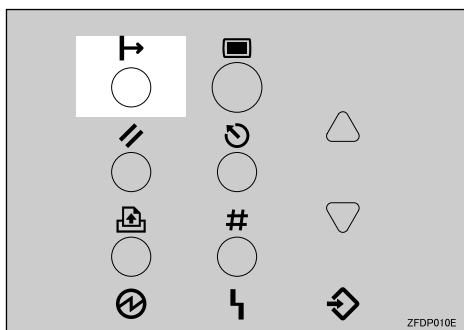

“Ready” appears on the panel display.



Specifying a Custom Paper Size for the Bypass Tray

- 1** Press **[Menu]**.

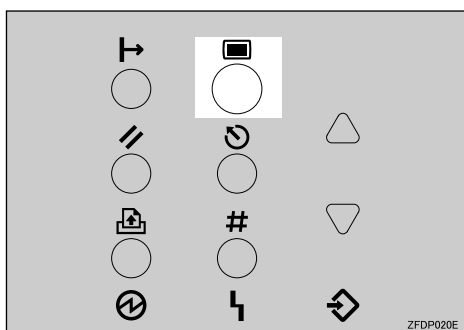

“Menu” appears on the panel display.

- 2** Press **[▲]** or **[▼]** to display the “Paper Input” menu.

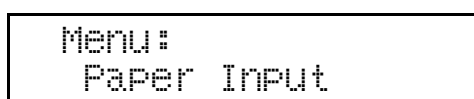

- 3** Press **[Enter #]**.

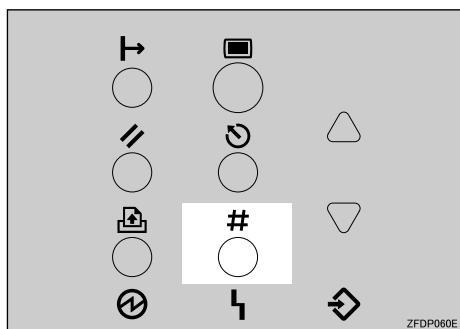

The following message appears on the panel display.

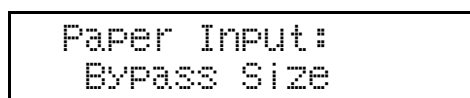

- 4** Press **[Enter #]**.

The currently selected paper size appears on the panel display.

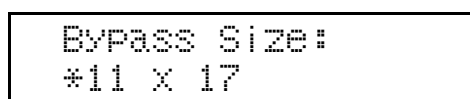

- 5** Press **[▲]** or **[▼]** to select "Custom Size".

- 6** Press **[Enter #]**.

The following message appears on the panel display.

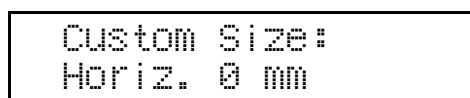

The unit on the panel display can be changed to inches with the control panel.

- 7** Press **[▲]** or **[▼]** to set the horizontal value.

8 Press **[Enter #]**.

The following message appears on the panel display.



9 Press **[▲]** or **[▼]** to set the vertical value.

10 Press **[Enter #]**. Wait for about two seconds.

11 After the panel display changes, press **[On Line]**.

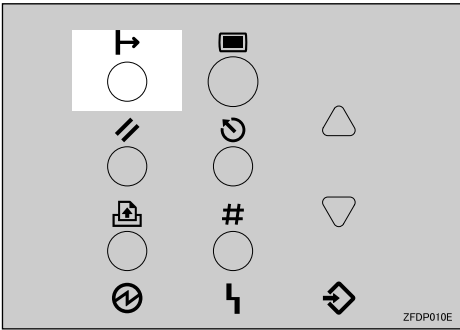

"Ready" appears on the panel display.

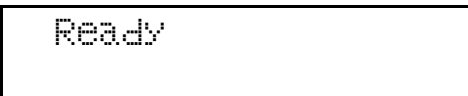

Loading Paper in the Optional Large Capacity Tray

This section describes instructions to load paper in the optional Large Capacity Tray RT36.

Reference

For more information on the size and feed direction of paper that can be set in the tray, see p.25 "Paper Sizes".

1 Check if the tray release button is lit. If it is not lit, press the button to light it.

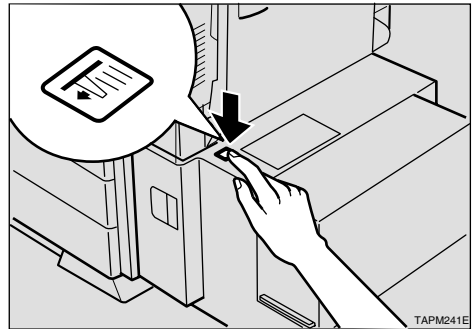

2 When the button stops blinking and is lit, open the top cover.

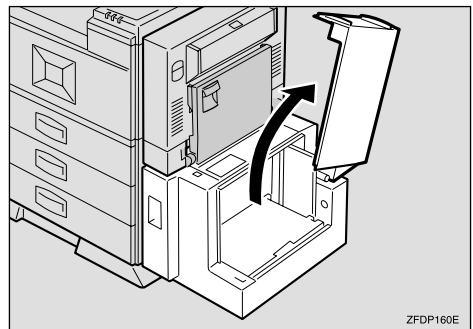

- 3 Load paper with the print side down by pressing the side of the stack to the wall.

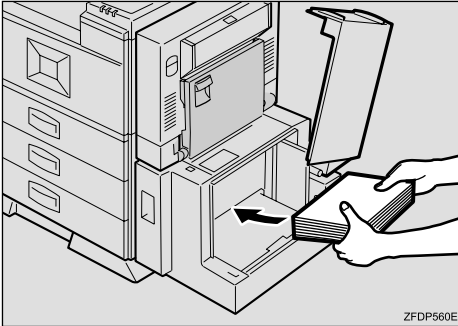

Important

- Confirm the top of the stack is not higher than the limit mark inside the tray.

- 4 Close the top cover.

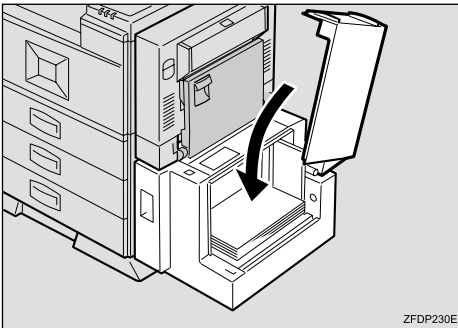

Note

- If the printer is in the Energy Saver mode when changing the paper size, Press **[Enter #]** before printing. This will update the size setting.

4. Sample Print/Locked Print

Sample Print

Use this function to print only the first set of a multiple-set print jobs. The remaining sets are saved on the optional Printer Hard Disk in the printer. The saved job can be printed or canceled from the printer's control panel.

Important

- When the power is turned off, the print job stored in the Printer Hard Disk and the error log will be deleted.

Limitation

- To use this function, the optional Printer Hard Disk must be installed to the printer.

Note

- If the application has a collate option, confirm that it is not selected before sending a print job. By default, Sample Print jobs are automatically collated by the printer driver. If the collate option is selected from the application [Print] dialog box, more pages than intended may be printed.
- You can identify the file you want to print by the User ID and the time when the job was stored.
- The actual number of pages the printer can save depends on the contents of the print images. For example, the printer can save up to 30 jobs or 2,000 pages. It depends on the data volume.

- If the first set of the Sample Print file is not as you expected and you do not want to print the remaining sets, delete the Sample Print file using the control panel. If you print the remaining sets of the Sample Print file, the job in the printer is deleted automatically.

Printing a Sample Print File

The following procedure describes how to print a Sample Print file with the PCL printer driver. For information about how to print a Sample Print file with the PostScript printer driver, see the PostScript3 Supplement on the CD-ROM labeled "Operating Instructions". For information about RPCS printer driver, see the Help file.

- 1** From an application, select the menu command to print.

The [Print] dialog box appears.

- 2** Open the Printer Properties.
- 3** From the [Job Type:] box on the [Setup] tab, select [Sample Print].
- 4** Click the [Details...] button.
- 5** In the [User ID:] box, type a User ID of up to eight alphanumeric characters.

Note

- This is used to identify the user associated with a job.
- The User ID can consist of up to eight alphanumeric (a-z, A-Z, 0-9) characters.

- 6** Click [OK].

7 After making all desired settings, click [OK].

8 Start printing from the application's [Print] dialog box.

The Sample Print job is sent to the printer and the first set is printed.

9 Check the print job to confirm whether the settings are acceptable.

If the settings are fine, go to step 10 to print the rest of the print job.

If not, you can delete the saved job. ⇒ p.47 "Deleting a Sample Print File"

10 On the printer's control panel, press [Menu].

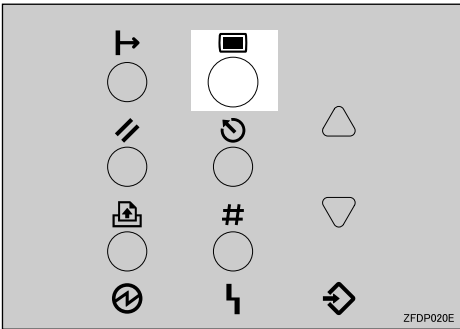

"Menu" appears on the panel display.

11 Press [▼] or [▲] to display the "Sample Print" menu.



12 Press [Enter #].

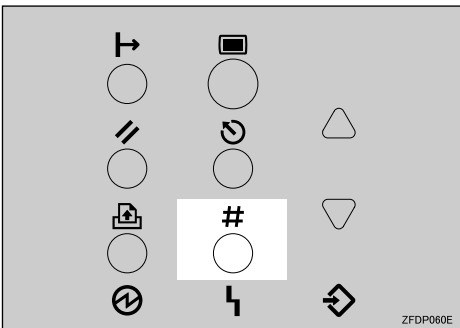

13 Press [▼] or [▲] to display the file you want to print, and then press [Enter #].



14 Confirm that "Print File" is displayed, and then press [Enter #].



Note

If you want to cancel the Sample Print, press [Escape].

15 Press [▲] or [▼] to enter the number of sets to print.

Note

You can enter up to 999 sets to print.



16 Press [Enter #] to print the file.

The following message appears on the panel display.

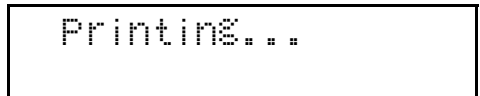

Note

The print job is deleted from the Printer Hard Disk after printing.

Deleting a Sample Print File

If you are not satisfied with the print-out, delete the Sample Print file.

- 1 Press **[Menu]**.

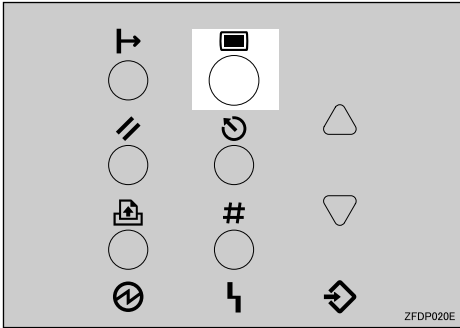

"Menu" appears on the panel display.

- 2 Press **[▼]** or **[▲]** to display the "Sample Print" menu .

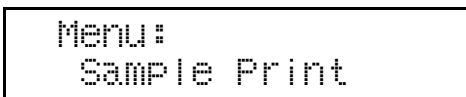

- 3 Press **[Enter #]**.

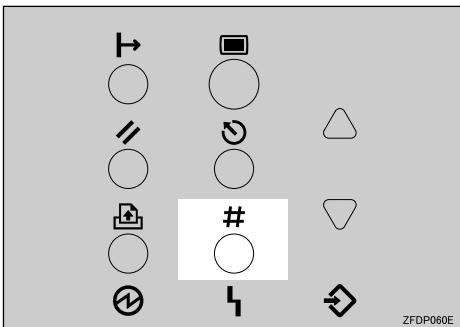

- 4 Press **[▼]** or **[▲]** to display the file you want to delete, and then press **[Enter #]**.



- 5 Press **[▼]** or **[▲]** to display "Delete File", and then press **[Enter #]**.



Note

- If you want to cancel the deletion of a Sample Print file, press **[Escape]**.

- 6 Confirm the file, and then press **[Enter #]** to delete the file.



The following message appears on the panel display.

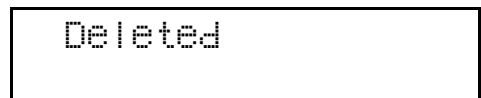

- 7 Press **[On Line]**.

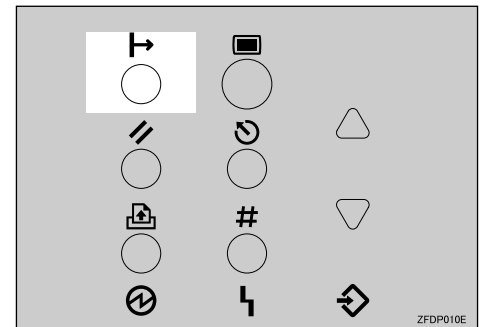

"Ready" appears on the panel display.



Checking the Error Log

You can see the error log of the files that are not stored in the Printer Hard Disk successfully.

Note

- The last error logs are displayed up to 20.

1 Press **[Menu]**.

"Menu" appears on the panel display.

2 Press **[▼]** or **[▲]** to display the "Sample Print" menu.



3 Press **[Enter #]**.

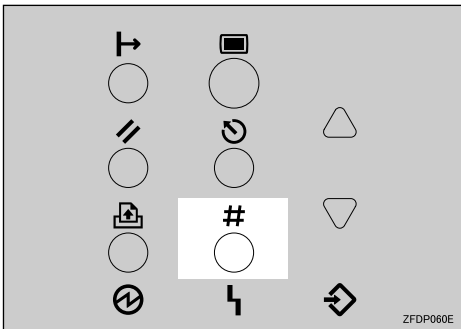

4 Press **[▼]** or **[▲]** to display "Error File(s)".

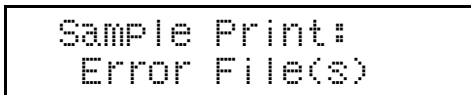

5 Press **[Enter #]**.

6 Press **[▼]** or **[▲]** to check the error log.

Note

- In order to print a file in the error log, print or delete the files that are stored in the Printer Hard Disk, and then make a setting to print again from the computer.

7 When finished checking, press **[Escape]**.

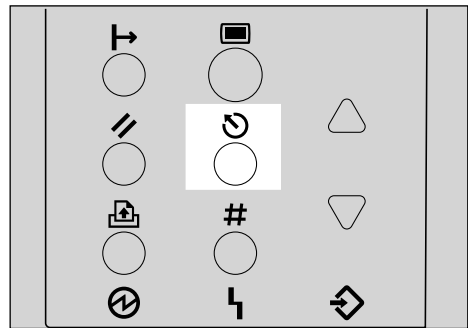

ZDDS024E

8 Press **[On Line]**.

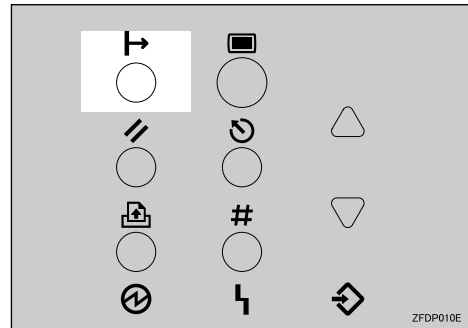

ZFDP010E

"Ready" appears on the panel display.

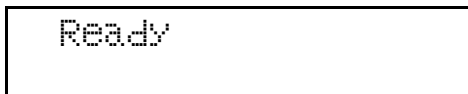

Locked Print

This function is useful when printing confidential documents in a network environment. First, spool the print job to the Printer Hard Disk, and then enter a password from the control panel to make prints.

Important

- When the power is turned off, the print job stored in the Printer Hard Disk and the error log will be deleted.

Limitation

- To use this function, the optional Printer Hard Disk must be installed to the printer.

Note

- If the application has a collate option, confirm that it is not selected before sending a print job. By default, Locked Print jobs are automatically collated by the printer driver. If the collate option is selected from the application **[Print]** dialog box, more pages than intended may be printed.
- You can identify the file you want to print by the User ID and the time when the job was stored.
- The actual number of pages the printer can save depends on the contents of the print images. For example, the printer can save up to 30 jobs or 2,000 pages. It depends on the data volume.
- After the Locked Print file is printed, the job in the printer is deleted automatically.

Printing a Locked Print File

The following procedure describes how to print a Locked Print file with the PCL printer driver. For information about how to print a Locked Print file with the PostScript printer driver, see the PostScript3 Supplement on the CD-ROM labeled "Operating Instructions". For information about RPCS printer driver, see the Help file.

- 1** From an application, select the menu command to print.

The **[Print]** dialog box appears.

- 2** Open the Printer Properties.

- 3** From the **[Job Type:]** box on the **[Setup]** tab, select **[Locked Print]**.

- 4** Click the **[Details:]** button.

- 5** In the **[User ID:]** box, type a User ID of up to eight alphanumeric characters.

Note

- This is used to identify the user associated with a job.
- The User ID can consist of up to eight alphanumeric (a-z, A-Z, 0-9) characters.

- 6** In the **[Password:]** box, type a password of four digits.

Note

- The password must be four digits (0-9).

- 7** Click **[OK]**.

- 8** After making all desired settings, click **[OK]**.

- 9** Start printing from the application's [Print] dialog box.

The Locked Print job is sent to the printer.

- 10** On the printer's control panel, press [Menu].

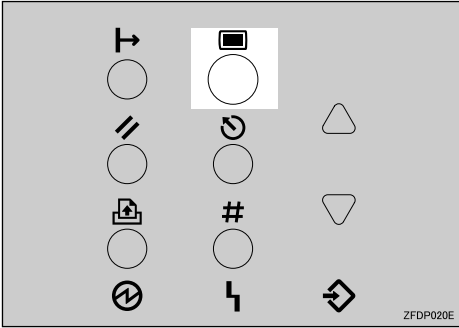

"Menu" appears on the panel display.

- 11** Press [▼] or [▲] to display "Locked Print" menu.



- 12** Press [Enter #].

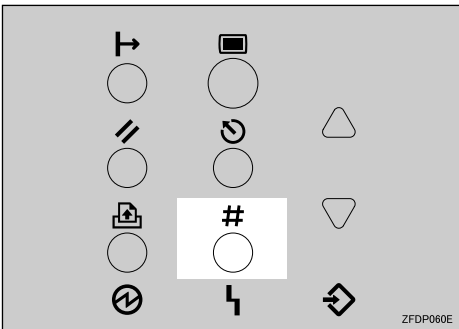

- 13** Press [▼] or [▲] to display the file you want to print, and then press [Enter #].



- 14** Enter the password you entered in step 6.

- 1** Press [▲] or [▼] to enter the leftmost digit of the password.



- 2** Press [Enter #].

The cursor moves to the next digit.

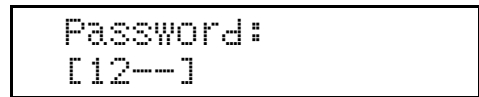

- 3** Repeat steps 1 and 2 to enter the remaining digit of the password, and then press [Enter #].

If the password is not correct, the following message appears and the panel display returns to the password menu. Enter the correct password.

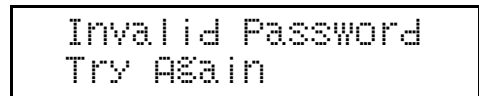

- 15** Confirm that "Print File" is displayed, and then press [Enter #].

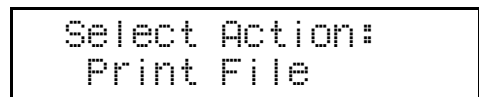

Note

- If you want to cancel the Locked Print, press [Escape].

- 16 Confirm the file, and then press **[Enter #]** to print the file.

```
Qty: 6(1-999)
Press # To Print
```

The following message appears on the panel display.

```
Printing...
```

Deleting the Locked Print File

- 1 Press **[Menu]**.

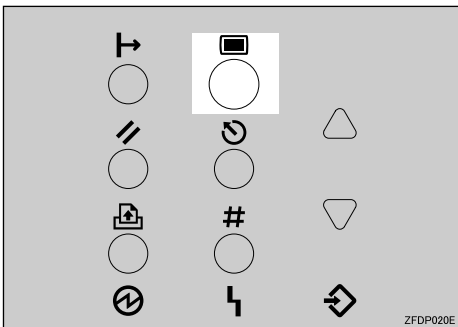

"Menu" appears on the panel display.

- 2 Press **[▼]** or **[▲]** to display the "Locked Print" menu.

```
Menu:
Locked Print
```

- 3 Press **[Enter #]**.

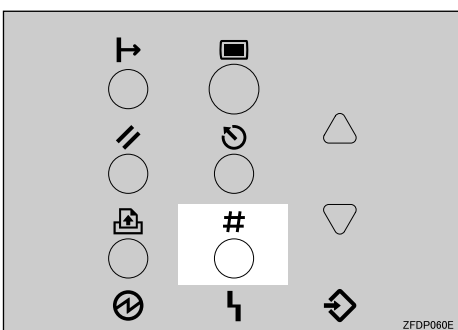

- 4 Press **[▼]** or **[▲]** to display the file you want delete, and then press **[Enter #]**.

```
Locked Print:
08:56 ABCD1234
```

- 5 Enter the password of the Locked Print file.

- 1 Press **[▲]** or **[▼]** to enter the leftmost digit of the password.

```
Password:
[1----]
```

- 2 Press **[Enter #]**.

The cursor moves to the next digit.

```
Password:
[12---]
```

- 3 Repeat steps 1 and 2 to enter the remaining password digits, and then press **[Enter #]**.

If the password is not correct, the following message appears and the panel display returns to the password menu. Enter the correct password.

```
Invalid Password
Try Again
```

- 6 Press **[▼]** or **[▲]** to display "Delete File", and then press **[Enter #]**.

```
Select Action:
Delete File
```

 **Note**

- If you want to cancel the Locked Print, press **[Escape]**.

7 Confirm the file, and then press **[Enter #]**.



The following message appears on the panel display.



8 Press **[On Line]**.

4

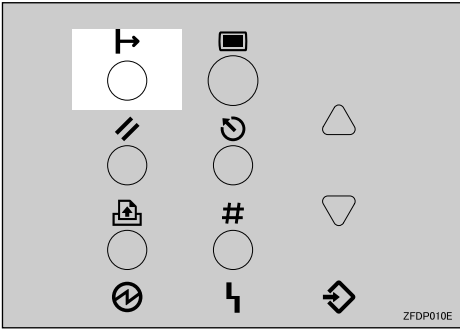

"Ready" appears on the panel display.



Checking the Error Log

You can see the error log of the files that are not stored in the Printer Hard Disk successfully.

Note

- The last error logs are displayed up to 20.

1 Press **[Menu]**.

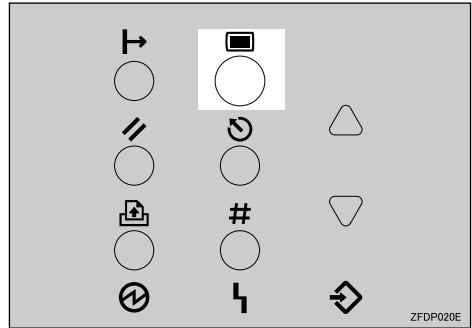

"Menu" appears on the panel display.

2 Press **[▼]** or **[▲]** to display the "Locked Print" menu.

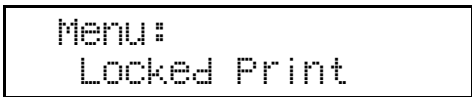

3 Press **[Enter #]**.

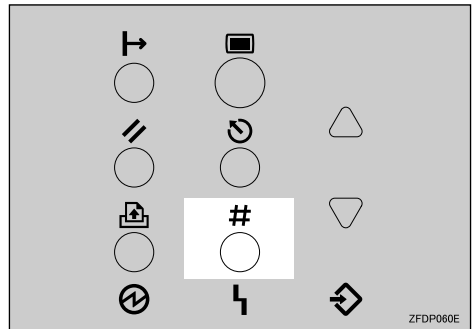

- 4** Press [▼] or [▲] to display "Error File(s)".

Locked Print:
Error File(s)

- 5** Press [Enter #].

- 6** Press [▼] or [▲] to check the error log.

 **Note**

- In order to print a file in the error log, print or delete the files that are stored in the Printer Hard Disk, and then make a setting to print again from the computer.

- 7** Press [On Line].

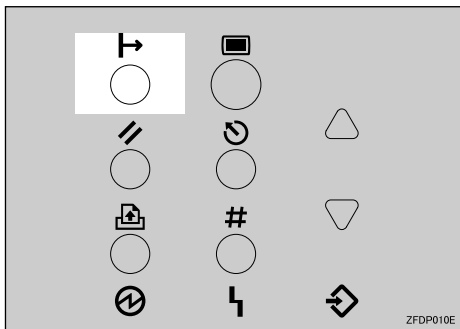

"Ready" appears on the panel display.

Ready

4

5. Troubleshooting

Error & Status Messages on the Control Panel

❖ Status Messages

Messages/Second messages	Status
Energy Save Mode	The printer is in Energy Saver (low-power) mode. No action is required.
Hex Dump Mode	The printer receives data in hexadecimal numbers in Hex Dump mode. Turn off the printer after printing, and then turn back on.
Loading Toner...	The printer is loading toner. Wait until "Ready" appears on the panel display.
Offline	The printer is offline. Set the printer online by pressing [On Line] to start printing.
Printing...	The printer is making prints. Wait for a while.
Processing...	The printer is processing the print job. Wait for a while.
Ready	The default ready message. The printer is ready for use. No action is required.
Resetting Job...	The printer is resetting the print job. Wait until "Ready" appears on the panel display.
Waiting...	The printer is waiting for the next data to print. Wait for a while.
Warming Up...	The printer is warming up and not ready. Wait until "Ready" appears on the panel display.

❖ Alert Messages

Messages/Second messages	Description	Solution
Add Staples	The staples are almost run out.	Replace the staple refill with a new one. See p.91 "Adding Staples".
Call Service: EC Power Off On /If Error Reoccur Call Service	An error has occurred in the printer.	First, turn the power switch off and then on. If the message appears again, call your sales or service representative.
Change Setting Bypass Tray /Paper Size Paper Type	The paper type and size setting on the tray differs from that of actual paper type and size in the tray.	Load { paper size and type } paper with the selected feed direction into tray. Printing will not automatically resume if the paper type, size and direction setting is incorrect. There are two methods to resume printing. <ol style="list-style-type: none"> ① Use the control panel to set the correct paper type, size and direction of the paper in tray. ② Press 【Form Feed】 and select the tray with the control panel.
Change Setting LCT /Paper Size Paper Type	The paper type and size setting on the tray differs from that of actual paper type and size in the tray.	Load { paper size and type } paper with the selected feed direction into tray. Printing will not automatically resume if the paper type, size and direction setting is incorrect. There are two methods to resume printing. <ol style="list-style-type: none"> ① Use the control panel to set the correct paper type, size and direction of the paper in tray. ② Press 【Form Feed】 and select the tray with the control panel.

Messages/Second messages	Description	Solution
Change Setting Tray # /Paper Size Paper Type	The paper type and size setting on the tray differs from that of actual paper type and size in the tray. #: tray number	Load { paper size and type } paper with the selected feed direction into tray. Printing will not automatically resume if the paper type, size and direction setting is incorrect. There are two methods to resume printing. ① Use the control panel to set the correct paper type, size and direction of the paper in tray. ② Press 【Form Feed】 and select the tray with the control panel.
Check Duplex Unit Cable	The Duplex Unit cable is not connected properly.	Connect it properly.
Close BridgeUnit Left Cover	The left cover of the Bridge Unit is not closed securely.	Close the cover securely.
Close BridgeUnit Middle Cover	The middle cover of the Bridge Unit is not closed securely.	Close the cover securely.
Close BridgeUnit Right Cover	The right cover of the Bridge Unit is not closed securely.	Close the cover securely.
Close Duplex Unit Cover	The cover of the Duplex Unit is open.	Close the cover of the Duplex Unit.
Close Finisher Cover	The front cover for the Finisher SR730 or the upper cover/front cover for the Finisher SR720 is open.	Close the cover.
Close Front Cover	The front cover is open.	Close the front cover.
Close Lower Right Cover	The lower vertical paper feed cover is open.	Close the lower vertical paper feed cover.
Close Mailbox Cover	The cover of the Mailbox is open.	Close the cover of the Mailbox.
Close Mailbox Front Cover	The front cover of the Mailbox is open.	Close the cover securely.
Close Mailbox Upper Cover	The upper cover of the Mailbox is open.	Close the cover securely.
Close Right Cover	The right cover or the upper vertical paper feed cover is open.	Close the cover.

Messages/Second messages	Description	Solution
Collate Cancelled	The collate feature has been canceled.	To print the image correctly, add memory to the printer, or reduce the resolution of the image.
Driver Setting Error (Memory)	The actual amount of memory installed does not match the setting of printer driver. The current print job has been canceled.	Configure the memory size correctly from the printer driver.
Duplex Cancelled	Duplex Print has been canceled.	To print the image correctly, add memory to the printer, or reduce the resolution of the image.
		Load paper into the tray indicated.
Exceeded Max. Pages (Collate)	An error has occurred in the collation table overflow.	To print the image correctly, add memory to the printer, or reduce the resolution of the image.
Exceeded Max. Stored Files	The Sample Print job or the Locked Print job to be sent from the computer will cause the maximum number of files to be exceeded.	Delete the stored files.
Exceeded Max. Stored Pages	The Sample Print job or the Locked Print job to be sent from the computer will cause the maximum number of storable pages to be exceeded.	Reduce the number of pages to print.
Hardware Problem DIMM	An error has occurred in the printer.	First, turn the power switch off and then on. If the message appears again, call your sales or service representative.
Hardware Problem Ethernet	An error has occurred in the Ethernet Board.	First, turn off the power switch and then on. If the message appears again, call your sales or service representative.
Hardware Problem Finisher	An error has occurred in the Finisher.	First, turn the power switch off and then on. If the message appears again, call your sales or service representative.

Messages/Second messages	Description	Solution
Hardware Problem HDD	An error has occurred in the optional Printer Hard Disk.	First, turn the power switch off and then on. If the message appears again, call your sales or service representative.
		Turn off the power switch. Replace the Printer Hard Disk and turn on the power switch. See <i>"Installing Printer Hard Disk Type 4510"</i> in the Setup Guide.
		Turn off the power switch. Remove the Printer Hard Disk and turn on the power switch. Note <input type="checkbox"/> If the Printer Hard Disk is not installed, you cannot send the Sample Print job, Locked Print job or download the font to Printer Hard Disk using the PS Utility for Mac.
Hardware Problem IEEE1394	An error has occurred in the optional 1394 Interface Unit.	First, turn the power switch off and then on. If the message appears again, call your sales or service representative.
		Turn off the power switch. Replace the 1394 Interface Unit and turn on the power switch. See <i>"Installing 1394 Interface Unit Type 4510"</i> in the Setup Guide.
		Turn off the power switch, remove the 1394 Interface Unit and turn on the power switch. Note <input type="checkbox"/> If you remove the 1394 Interface Unit, you cannot send print jobs via the 1394 Interface Unit. You can only send print jobs to the printer via the parallel cable connection.
Hardware Problem LCT	An error has occurred in the Large Capacity Tray.	First, turn the power switch off and then on. If the message appears again, call your sales or service representative.

Messages/Second messages	Description	Solution
Hardware Problem NV-RAM	The printer detected a Memory Switch error.	Remove and reinstall the NV-RAM.
Hardware Problem Option RAM	An error has occurred in the optional Memory Unit.	First, turn the power switch off and then on. If the message appears again, call your sales or service representative.
		Turn off the power switch, Replace the Memory Unit, and then turn on the power switch. See " <i>Installing Memory Unit TypeC</i> " in the Setup Guide.
		Turn off the power switch, remove the Memory Unit, and then turn on the power switch. Note <input type="checkbox"/> If you remove the Memory Unit, you must set up the option with the printer driver. If you are using Windows 95/98/Me, Windows 2000 and Windows NT 4.0, see " <i>Installing the Printer Driver and Software</i> " in the Setup Guide. <input type="checkbox"/> In this case, you might not be able to print complex print jobs.
Hardware Problem Parallel I/F	An error has occurred in the parallel I/F.	First, turn the power switch off and then on. If the message appears again, call your sales or service representative.
Hardware Problem Shift Tray	An error has occurred in the shift motor of the shift tray.	First, turn the power switch off and then on. If the message appears again, call your sales or service representative.
Hardware Problem Staple Unit	An error has occurred in the staple unit.	First, turn the power switch off and then on. If the message appears again, call your sales or service representative.
Hardware Problem Tray #	An error has occurred in the indicated tray. #: tray number	First, turn the power switch off and then on. If the message appears again, call your sales or service representative.

Messages/Second messages	Description	Solution
HDD Full	The optional Printer Hard Disk is full. The Sample Print job or Locked Print job to be sent from the computer is too large to store.	Delete any unwanted files.
HDD Not Installed	You cannot print the sample print and the Locked Print jobs, because the optional Printer Hard Disk is not installed.	Install the Printer Hard Disk. See " <i>Installing Printer Hard Disk Type 4510</i> " in the Setup Guide.
I/O Buffer Overflow	There is too much data for the I/O buffer to handle.	Make sure the interface cable is inserted into the printer and your computer securely.
		Make sure the interface cable is not damaged or broken.
		Increase the size of the I/O buffer.
Invalid Password Try Again	The password was not entered correctly.	Wait for two seconds until the previous display appears. Then enter the password correctly.
Load Paper /Paper Size Paper Type	The paper type and size settings for this tray do not match the size and type of paper actually loaded.	Load paper that matches the paper size and type settings. Printing will not automatically resume if the paper type, size and direction settings are incorrect. There are two methods to resume printing. ① Use the control panel to set the correct paper type, size and direction of the paper in tray. ② Press 【Form Feed】 and select the tray with the control panel.
Load Paper Bypass Tray /Paper Size Paper Type	There is no paper in the tray.	Load paper into the tray.
Load Paper LCT /Paper Size Paper Type	There is no paper in the tray.	Load paper into the tray.

Messages/Second messages	Description	Solution
Load Paper Tray # /Paper Size Paper Type	There is no paper left in this tray. #: tray number	Load paper into the tray indicated.
Memory Overflow	The printer identified a PS3 work area overflow error.	Increase the memory capacity or decrease the file size to be downloaded.
Menu Protected Cannot Change	The menu is protected and the settings cannot be changed.	Wait for two seconds until the previous display appears.
No Files Exist	There are no files available for the Sample Print job or the Locked Print job.	Wait for two seconds until the previous display appears.
Output Tray Changed	The output tray has been changed. The tray in the paper feed path is not set correctly when the printer receives the print job.	Select the output tray correctly.
Paper Invalid for Duplex:Bypass /Change Setting or Form Feed	The paper selected cannot be used for duplex printing.	Select the tray or load appropriate paper so that duplex printing can be performed. There are two methods to resume printing. ① Use the control panel to set the correct paper size and direction of the paper in tray. ② Press 【Form Feed】 and select the tray with the control panel. When 【Form Feed】 cannot be performed, change the paper setting.
Paper Invalid for Duplex:LCT /Change Setting or Form Feed	The paper selected cannot be used for duplex printing.	Select the tray or load appropriate paper so that duplex printing can be performed. There are two methods to resume printing. ① Use the control panel to set the correct paper size and direction of the paper in tray. ② Press 【Form Feed】 and select the tray with the control panel. When 【Form Feed】 cannot be performed, change the paper setting.

Messages/Second messages	Description	Solution
Paper Invalid for Duplex:Tray# /Change Setting or Form Feed	The paper selected cannot be used for duplex printing. #: tray number	Select the tray or load appropriate paper so that duplex printing can be performed. There are two methods to resume printing. ① Use the control panel to set the correct paper size and direction of the paper in tray. ② Press 【Form Feed】 and select the tray with the control panel. When 【Form Feed】 cannot be performed, change the paper setting.
Print Overrun	A Print overrun occurred on a file being printed. Only a part of the data on the page will be printed, and the print job is suspended, or the current print job has been canceled.	To print the image correctly, add memory to the printer or reduce the resolution of the image.
Punch Cancelled	The punch feature has been canceled.	Confirm if the paper size, feed direction or paper type is supported for the punch function.
Punch-hole Chips are Full	The punch waste box is full.	Remove paper chips.
P=07 I=9FC01234 Power Off On /If Error Reoccur Call Service	An error has occurred in the controller.	First, turn the power switch off and then on. If the message appears again, call your sales or service representative.
Remove Misfeed A,Y:Input Tray	There is paper in an input tray.	Remove the misfed paper. See p.80 "Removing Misfed Paper".
Remove Misfeed B,C,D:Internal	There is paper in the printer.	Remove the misfed paper. See p.80 "Removing Misfed Paper".
Remove Misfeed R:Finisher	There is paper in the Finisher.	Remove the misfed paper. See p.80 "Removing Misfed Paper".
Remove Misfeed U:LCT	There is paper in the Large Capacity Tray.	Remove the misfed paper. See p.80 "Removing Misfed Paper".
Remove Misfeed W:Mailbox	There is paper in the Mailbox.	Remove the misfed paper. See p.80 "Removing Misfed Paper".

Messages/Second messages	Description	Solution
Remove Misfeed Z:Duplex Unit	There is paper in the Duplex Unit.	Remove the misfed paper. See p.80 "Removing Misfed Paper".
Remove Paper All Output Trays	All output trays are full, and the print job is suspended.	Remove paper from the trays, and the print job will be resumed automatically.
Remove Paper Duplex Unit	There is paper in the Duplex Unit.	Remove paper from the Duplex Unit.
Remove Paper Fin. Proof Tray	The Finisher proof tray is full, and the print job is suspended.	Remove paper from the tray, and the print job will be resumed automatically.
Remove Paper Fin. Shift Tray	The Finisher shift tray is full, and the print job is suspended.	Remove paper from the tray, and the print job will be resumed automatically.
Remove Paper Inside Finisher	There is paper in the Finisher.	Remove paper from the Finisher.
Remove Paper Mailb.ProofTray	The Mailbox proof tray is full, and the print job is suspended.	Remove paper from the tray, and the print job will be resumed automatically.
Remove Paper Mailbox Tray #	The Mailbox is full, and the print job is suspended. #: tray number	Remove paper from the Mailbox, and the print job will be resumed automatically.
Remove Paper Standard Tray	The standard tray is full, and the print job is suspended.	Remove paper from the standard tray, and the print job will be resumed automatically.
Replace Maintenance Kit	It is time to replace parts included in the Maintenance Kit.	Replace parts.
Replace Toner Bottle	The toner bottle is not set correctly or toner is almost run out.	Set the toner bottle correctly. See p.80 "Removing Misfed Paper".
Toner Dust is Full	The toner dust is full.	Call your sales or service representative.
Replace Transfer Unit	It is time to replace the transfer unit.	Replace the transfer unit.
Reset Bypass Correctly	The Bypass Tray is not set correctly or is not set.	Set the Bypass Tray correctly.
Reset Duplex Unit Correctly	The Duplex Unit is not set correctly.	Set the Duplex Unit correctly. If the message appears again, call your sales or service representative.
	An error has occurred in the Duplex Unit.	
Reset Fusing Unit Correctly	The fusing unit is not set correctly.	Set the fusing unit correctly, or set the proper fusing unit.

Messages/Second messages	Description	Solution
Reset LCT Correctly	The Large Capacity Tray is not set correctly or is not set.	Set the Large Capacity Tray correctly.
Reset Tray Correctly	The tray selected by the auto tray select is not set or is not set correctly.	Set the tray correctly.
Reset Tray # Correctly	The input paper tray is not set correctly. #: tray number	Set the input paper tray correctly.
RPCS Graphic Error	There is not enough graphics memory to print the data.	Specify the correct memory capacity in the [Change Accessories...] option in the RPCS printer driver's print settings tab. For more information, see <i>"Installing the RPCS Printer Driver"</i> in the Setup Guide.
		To print the image correctly, add memory to the printer, or reduce the resolution of the image.
RPCS Memory Overflow	A memory overflow occurred during the print job. After a part of the data on the page is printed, the print job is suspended.	Specify the correct memory capacity in the [Change Accessories...] option in the RPCS printer driver's print settings tab. For more information, see <i>"Installing the RPCS Printer Driver"</i> in the Setup Guide.
		To print the image correctly, add memory to the printer, or reduce the resolution of the image.
RPCS Syntax Error	An error has occurred in the syntax.	Specify the correct memory capacity in the [Change Accessories...] option in the RPCS printer driver's print settings tab. For more information, see <i>"Installing the RPCS Printer Driver"</i> in the Setup Guide.
		To print the image correctly, add memory to the printer, or reduce the resolution of the image.
SC XXX- X Power Off On /If Error Reoccur Call Service	The Service Code or SC number indicates the problem.	Turn the power switch off and on. If the message appears again, contact your sales or service representative.

Messages/Second messages	Description	Solution
Staple Cancelled	The staple feature has been canceled.	Confirm if the paper size, feed direction or paper type is supported for the staple function.
Toner Is Almost Empty	The toner is almost run out.	Prepare a new toner bottle. If the image density gets too light, replace the toner bottle with a new one. See p.97 "Replacing the Toner Bottle".
Waste Toner is Almost Full	Waste toner bottle is almost full of toner dust.	Call your sales or service representative.
Waste Toner is Full	Waste toner bottle is full of toner dust.	Call your sales or service representative.

Getting Printer Information over the Network

Printer current status

You can check the printer's status using the telnet command.

❖ telnet

Use the stat command.



❖ UNIX

Use the lpq or lpstat command or stat parameter of rsh, rcp, or ftp.

Reference

For more information, see *“Remote Maintenance by telnet”* in the Network Printing Guide on the CD-ROM labeled *“Operating Instructions”*.

Messages	Description	Solution
Call Service Center: SC	An error has occurred in the printer.	First, turn the power switch off and then on. If the message appears again, call your sales or service representative.
Cover Open: Bridge	The cover of the Bridge Unit is open.	Close the cover.
Cover Open: Duplex Unit	The cover of the optional Duplex Unit is open.	Close the cover of the optional Duplex Unit.
Close Open: Finisher	The cover of the Finisher SR730 is open.	Close the cover.
Cover Open: Front Cover	The front cover of the printer is open.	Close the front cover.
Cover Open: Lower Right Cover	The lower vertical paper feed cover is open.	Close the cover.
Cover Open: Mailbox	The cover of the Mailbox is open.	Close the cover.
Cover open: Right Cover	The upper vertical paper feed cover is open.	Close the cover.
Empty: Toner	The printer is out of toner.	Replace with a new toner bottle.
Energy Saver Mode	The printer is in Energy Saver Mode.	No action is required.
Error: DIMM	An error has occurred in the printer.	First, turn the power switch off and then on. If the message appears again, call your sales or service representative.
Error: Ethernet	An error has occurred in the Ethernet Board.	First, turn the power switch off and then on. If the message appears again, call your sales or service representative.

Messages	Description	Solution
<p>Error: HDD</p>	<p>An error has occurred in the optional Printer Hard Disk.</p>	<p>First, turn the power switch off and then on. If the message appears again, call your sales or service representative.</p>
		<p>Turn off the power switch. Replace the Printer Hard Disk and turn on the power switch. See <i>"Installing Printer Hard Disk Type 4510"</i> in the Setup Guide.</p>
		<p>Turn off the power switch. Remove the Printer Hard Disk and turn on the power switch.</p> <p> Note</p> <p><input type="checkbox"/> If the Printer Hard Disk is not installed, you cannot send the Sample Print job, Locked Print job or download the font to Printer Hard Disk using the PS Utility for Mac.</p>
<p>Error: IEEE 1394</p>	<p>An error has occurred in the optional 1394 Interface Unit.</p>	<p>First, turn the power switch off and then on. If the message appears again, call your sales or service representative.</p>
		<p>Turn off the power switch. Replace the 1394 Interface Unit and turn on the power switch. See <i>"Installing 1394 Interface Unit Type 4510"</i> in the Setup Guide.</p>
		<p>Turn off the power switch, remove the 1394 Interface Unit and turn on the power switch.</p> <p> Note</p> <p><input type="checkbox"/> If you remove the 1394 Interface Unit, you cannot send print jobs via the 1394 Interface Unit. You can only send print jobs to the printer via the parallel cable connection.</p>
<p>Error: NVRAM</p>	<p>The printer detected a Memory Switch error.</p>	<p>Remove and reinstall the NVRAM.</p>

Messages	Description	Solution
Error: Optional RAM	An error has occurred in the optional Memory Unit.	First, turn the power switch off and then on. If the message appears again, call your sales or service representative.
		Turn off the power switch, Replace the Memory Unit, and then turn on the power switch. See " <i>Installing Memory Unit TypeC</i> " in the Setup Guide.
		Turn off the power switch, remove the Memory Unit, and then turn on the power switch.  Note <input type="checkbox"/> If you remove the Memory Unit, you must set up the option with the printer driver. If you are using Windows 95/98/Me, Windows 2000 and Windows NT 4.0, see " <i>Installing the Printer Driver and Software</i> " in the Setup Guide. <input type="checkbox"/> In this case, you might not be able to print complex print jobs.
Error: Parallel I/F	An error has occurred in the parallel interface board.	First, turn the power switch off and then on. If the message appears again, call your sales or service representative.
Full: Finisher Proof Tray	The proof tray of the optional Finisher SR730 is full.	Remove paper from the tray.
Full: Finisher Shift Tray	The shift tray of the optional Finisher SR730 is full.	Remove paper from the tray.
Full: Hole Punch Receptacle	The punch waste box in the Finisher SR730 is full.	Remove punch waste.
Full: Mailbox Proof Tray	The proof tray of the optional Mailbox is full.	Remove paper from the tray.
Full: Mailbox Tray #	The indicated output tray of the optional Mailbox is full. #: tray number	Remove paper from the tray.
Full: Standard Tray	The standard output tray is full.	Remove paper from the tray.
Full: Waste Toner	The waste toner bottle is full of toner dust.	Call your sales or service representative.

Messages	Description	Solution
Low: Staples	The staples in the optional Finisher SR730 is almost run out.	Prepare a new staple cartridge.
Low: Toner	The toner is almost run out.	Prepare a new toner bottle.
Malfunction: Duplex Unit	An error has occurred in the Duplex Unit.	Reinstall the Duplex Unit. If the message appears again, call your sales or service representative.
Malfunction: Finisher	An error has occurred in the optional Finisher SR730.	Reinstall the Finisher. If the message appears again, call your sales or service representative.
Malfunction: LCT	An error has occurred in the optional Large Capacity Tray.	Reinstall the Large Capacity Tray. If the message appears again, call your sales or service representative.
Malfunction: Staple Unit	An error has occurred in the staple unit in the Finisher SR730.	Reinstall the staple unit. If the message appears again, call your sales or service representative.
Malfunction: Tray #	An error has occurred in the indicated tray. #: tray number	First, turn the power switch off and then on. Reinstall the tray. If the message appears again, call your sales or service representative.
Mismatch: Paper Size	The paper size setting of the tray differs from that of actual paper size in the tray.	Load paper of the indicated paper size into the paper tray being used. See p.25 "Paper and Other Media Supported by This Printer".
Mismatch: Paper Size and Type	The paper size and type setting of the tray differs from that of actual paper type in the tray.	Load paper of the indicated paper size and type into the paper tray being used. See p.25 "Paper and Other Media Supported by This Printer".
Mismatch: Paper Type	The paper type setting of the tray differs from that of actual paper type in the tray.	Load paper of the indicated paper type into the paper tray being used. See p.25 "Paper and Other Media Supported by This Printer".
Nearly Full: Waste Toner	The waste toner bottle is almost full of toner dust.	Call your sales or service representative.
No Paper	There is no paper in the tray.	Load paper in the tray. See p.33 "Loading Paper and Other Media".

Messages	Description	Solution
Not Detected: Duplex Unit	The optional Duplex Unit is not set correctly.	Set the optional Duplex Unit correctly. If the message appears again, call your sales or service representative.
Not Detected: Fusing Unit	The fusing unit is not set correctly.	Set the fusing unit correctly. If the message appears again, call your sales or service representative.
Not Detected: User Selected Tray	The selected tray is not set correctly.	Set the selected tray correctly. If the message appears again, call your sales or service representative.
Paper in Duplex Unit	There is paper in the Duplex Unit.	Remove paper from the Duplex Unit.
Paper in Finisher	There is paper in the optional Finisher SR730.	Remove paper from the Finisher.
Paper Misfeed: Duplex Unit	There is misfeed in the Duplex Unit.	Remove the misfed paper. See p.89 "When "Remove Misfeed Z:Duplex Unit" Appears".
Paper Misfeed: Finisher	There is misfeed in the optional Finisher.	Remove the misfed paper. See p.84 "When "Remove Misfeed R:Finisher" Appears".
Paper Misfeed: Input Tray	There is misfeed in the printer.	Remove the misfed paper. See p.80 "When "Remove Misfeed A,Y:Input Tray" Appears".
Paper Misfeed: Internal	There is misfeed in the printer.	Remove the misfed paper. See p.82 "When "Remove Misfeed B,C,D:Internal" Appears".
Paper Misfeed: LCT	There is misfeed in the optional Large Capacity Tray.	Remove the misfed paper. See p.86 "When "Remove Misfeed U:LCT" Appears".
Paper Misfeed: Mailbox	There is misfeed in the Mailbox.	Remove the misfed paper. See p.87 "When "Remove Misfeed W:Mailbox" Appears".
Printer is not ready	An error has occurred in the printer.	Solve the problem to make prints.
Ready	The printer is ready for use.	No action is required.
Replace Maintenance Kit	It is time to replace parts included in the Maintenance Kit.	Replace parts.
Warming Up	The printer is warming up.	Wait until "Ready" appears on the panel display.

Printer configuration

You can check the printer configuration using telnet.

❖ **telnet**

Use the info command.

❖ **UNIX**

Use the info parameter of rsh, rcp, or ftp.

 **Reference**

For more information, see “Remote Maintenance by telnet” in the Network Printing Guide on the CD-ROM labeled “Operating Instructions”.

 **Note**

“*” (asterisk) is displayed with the current setting.

Regarding *1–*6, see the following tables.



















5

Item	Description
Printer System	Version of the printer
Network Board	Version of the network board
Input Tray	
No.	ID number of the paper tray
Name	Name of the paper tray* ¹
PaperSize	Paper size loaded in the paper tray* ²
Status	Current status of the paper tray* ³
Output Tray	
No.	ID number of the output tray
Name	Name of the output tray* ⁴
Status	Current status of the output tray* ⁵
Emulation	
No.	ID number of the emulation used by the printer
Name	Name of the emulation used in the printer
Version	Version of the emulation
Program	
No.	ID number of the program
Name	Name of the program

❖ *1 Input Tray: Name

Name	Description
Tray 1	The upper standard tray
Tray 2	The lower standard tray
Tray 3	The upper tray of the optional Paper Bank
Tray 4	The lower tray of the optional Paper Bank
Large Capacity Tray or LCT	The optional Large Capacity Tray
Bypass Tray	Bypass Tray

❖ *2 Input Tray: Paper Size

Paper Size	Description
A3 (297 × 420)	A3 
B4 JIS (257 × 364)	B4 
A4 (210 × 297)	A4 
A4 (297 × 210)	A4 
B5 JIS (182 × 257)	B5 
B5 JIS (257 × 182)	B5 
A5 (148 × 210)	A5 
A5 (210 × 148)	A5 
A6 (105 × 148)	A6 
11 × 17	279 × 432 
8 1/2 × 14	LG/216 × 356 
8 1/2 × 11	LT/216 × 279 
11 × 8 1/2	LT/279 × 216 
5 1/2 × 8 1/2	140 × 216 
7 1/4 × 10 1/2	184 × 267 
10 1/2 × 7 1/4	267 × 184 
8 1/4 × 13	210 × 330 
8 1/2 × 13	216 × 330 
8 × 13	203 × 330 
Custom Size	Custom Size

❖ ***3 Input Tray: Status**

Status	Description
Normal	There is no problem with the printer.
PaperEnd	There is no paper in the paper tray
NoInputTray	The tray is not set
Error	Other error

❖ ***4 Output Tray: Name**

Name	Description
Standard Tray	Standard output tray
Print Post Proof Tray	Mailbox proof tray
Print Post Tray 1 - Tray 9	Mailbox tray 1 to 9
Finisher Shift Tray	Finisher SR730 shift tray
Finisher Proof Tray	Finisher SR730 proof tray

❖ ***5 Output Tray: Status**

Status	Description
Normal	There is no problem with the printer.
PaperExist	There is paper in the output tray
OverFlow	Output tray is full of paper
Error	Other error

Printer Does Not Print

Possible Cause	Solutions
Is the power on?	Confirm that the cable is securely plugged into the power outlet and the printer. Turn on the power switch.
Is the On Line indicator on?	Press [On Line] so the indicator lights.
Is the Error indicator on?	Check the error message on the panel display and take the required action.
Is paper loaded?	Load paper into the paper tray or on the Bypass Tray. See p.33 "Loading Paper and Other Media".
Can you print a configuration page?	If you cannot print a test page, it probably indicates a printer malfunction. Contact your sales or service representative. See p.108 "List/Test Print Menu". If you can print a configuration page but cannot get the printer to print when you issue a print command from the computer, it probably means there is a problem with the computer. Note that large or complex data takes a long time to print.
Is the interface cable connecting the printer to the computer connected securely?	Connect the interface cable properly. If there are any connectors or screws, confirm that they are fastened securely.
Are you using the correct interface cable?	The type of interface cable you should use depends on the computer. Be sure to use the correct one. If the cable is damaged or worn, replace it with a new one.
Is the paper feed roller clean?	Clean the paper feed roller if it is dirty.

Possible Cause	Solutions
<p>Is the Data In indicator blinking or lit after starting the print job?</p>	<p>If not blinking or lit, the data is not being sent to the printer.</p> <ul style="list-style-type: none"> ❖ If the printer is connected to the computer using the interface cable <p>Make sure the printer port settings are correct. For a parallel port connection, port LPT1 or LPT2 should be set.</p> <ul style="list-style-type: none"> • Windows 95/98/Me <ol style="list-style-type: none"> ① Click [Start], point to [Settings], and then click [Printers]. ② Click to select the icon of the printer. Next, on the [File] menu, click [Properties]. ③ Click the [Details] tab. ④ Check the [Print to the following port] box to confirm that the correct port is selected. • Windows 2000 <ol style="list-style-type: none"> ① Click [Start], point to [Settings], and then click [Printers]. ② Click to select the icon of the printer. Next, on the [File] menu, click [Properties]. ③ Click the [Port] tab. ④ Check the [Print to the following port] box to confirm that the correct port is selected. • Windows NT 4.0 <ol style="list-style-type: none"> ① Click [Start], point to [Settings], and then click [Printers]. ② Click to select the icon of the printer. Next, on the [File] menu, click [Properties]. ③ Click the [Port] tab. ④ Check the [Print to the following port] box to confirm that the correct port is selected. ❖ Network Connection <p>Contact your network administrator.</p>
<p>Do you print via a network?</p>	<p>Confirm that the "Ethernet" setting is correct from the control panel. See p.122 "Host Interface Menu".</p> <p>The setting governs the data transfer speed used by the Network Interface Board. Three options are available:</p> <ul style="list-style-type: none"> • Auto (default) • 100 Mbps • 10 Mbps <p> Note</p> <ul style="list-style-type: none"> <input type="checkbox"/> For details about the appropriate setting to use on your network, contact your network administrator.

Possible Cause	Solutions
Is the optional 1394 Interface Unit installed correctly?	<p>Confirm that the 1394 interface cable is securely plugged into the power outlet and the printer.</p> <p>Turn on the power switch.</p> <p>Use the 1394 Interface Unit tool located in the following folder on the CD-ROM:</p> <p>\UTILITY\1394\</p> <p> Reference</p> <p>For more information about using the 1394 Interface Unit tool, see the readme file on the CD-ROM.</p>

 **Note**

- If you cannot solve the problem by taking the preceding actions, contact your sales or service representative.

Other Printing Problems

5

Status	Possible Causes, Descriptions, and Solutions
<p>The print side of the page is a hazy gray.</p>	<p>Adjust the image density. See p.99 "Making Printer Settings with the Control Panel".</p>
	<p>If paper is curled, correct it.</p>
	<p>Check if the size selected with the paper tray dial matches that selected with the control panel. If not, select the correct size that matches the size and feed direction loaded in the tray. If you print something after printing on the paper whose size is smaller than the actual document size, the back of the next output might get dirty. See p.33 "Loading Paper and Other Media".</p>
	<p>If you continuously print data that contains extremely small amount of words or images in the printable area, the printed side of the page could be a hazy gray. Adjust the image density. See p.99 "Making Printer Settings with the Control Panel".</p>
<p>Image quality varies when printing on thick paper or on OHP transparencies.</p>	<p>Switch to Thick Paper mode.</p> <ul style="list-style-type: none"> • When toner is not fused enough, set it to "On". • When the image is blurred, set it to "----". <p>See p.104 "Paper Input Menu".</p>
<p>Some parts of the print image are not clear.</p>	<p>Make the image density darker. See p.112 "Maintenance Menu".</p>
	<p>If Toner Saving mode is selected using the control panel, the whole image gets lighter.</p>
<p>The print image is not clear.</p>	<p>Due to a sudden change in temperature, condensation might appear inside the printer, reducing print quality. If this occurs, when you move the printer from a cold room to a warmer room, do not use the printer until it acclimatizes to the temperature.</p>
<p>Multiple pages are fed through the printer at once.</p>	<p>Clean the friction pad if it is dirty.</p>
	<p>Remove all paper from the tray and fan it gently to get air between the sheets. After that, load it back into the tray.</p>
<p>The image is printed on the reverse side of the paper.</p>	<p>Set the paper the other way up.</p>
<p>Paper misfeeds occur frequently.</p>	<p>Check the paper size settings. The size set with the paper size dial might be different from the actual paper size. Make the correct dial setting. See p.33 "Loading Paper and Other Media".</p>
	<p>Use the recommended paper. Avoid using curled, folded, wrinkled, perforated or glossy paper.</p>
	<p>Clean the paper feed roller, friction pad and/or registration roller, if they are dirty.</p>

Status	Possible Causes, Descriptions, and Solutions
The control panel error message stays on after removing the misfed paper.	Open the front cover of the printer and then close it. See p.80 "Removing Misfed Paper".
Paper is not fed from the selected tray.	Check the paper size settings. The size selected with the paper size dial might be different from the actual paper size. Make the correct dial setting. See p.33 "Loading Paper and Other Media".
	When using the Bypass Tray, set the paper size using the control panel. See p.33 "Loading Paper and Other Media".
	When you are using a Windows operating system, the printer driver settings override those set using the control panel. Set the desired output tray using the printer driver. See the driver's online Help file.
The printed image is different from the image on the computer.	When you use some functions, such as enlargement and reduction, the layout of the image might be different from that shown in the computer display.
It takes too much time to resume printing.	The data is so large or complex that it takes time to process it. If the Data In indicator is blinking, the data processing is being done. Just wait until it resumes.
	Changing the paper feed direction may sometimes reduce the time to resume printing.
The image is printed in the wrong orientation.	Set the correct orientation under the "PCL Menu" with the control panel. See p.127 "PCL Menu".
	Confirm that the setting of orientation has been set in the application you use.
	Set the correct paper size and feed direction that matches tray settings on the RPCS printer driver.
Part of the image cannot be printed.	A paper size which is smaller than that selected in the application is used for printing. Load the correct size of paper.
Network configurations you have made do not become effective.	Print a configuration page and check the network settings.

 **Note**

- If the problem cannot be solved, contact your sales or service representative.

Removing Misfed Paper

When a paper misfeed occurs, an error message appears on the panel display. The procedure you should follow to remove the misfed paper depends on the location of the misfeed, which is indicated on the panel display.

⚠ CAUTION:

- When removing misfed paper, do not touch the fusing section because it becomes very hot.

⚠ Important

- ❑ More than one misfed area might be indicated. In this case, check every applicable area. See the following charts shown in the illustration.

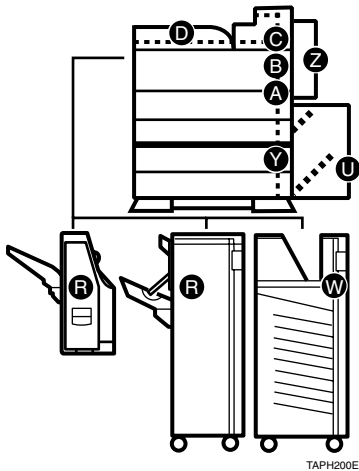

- ❑ If paper continues to misfeed, check the following points.
 - Confirm that the setting of the paper size dial matches the size and feed direction of the paper loaded in the paper tray.
 - Confirm that the toner bottle is set correctly.
- ❑ If paper misfeeds still occur, contact your sales or service representative.
- ❑ Do not leave any torn paper scraps within the printer.

When "Remove Misfeed A,Y:Input Tray" Appears

- 1 Open the Bypass Tray (①), and then open the Duplex Unit by pushing the catch upwards (②).

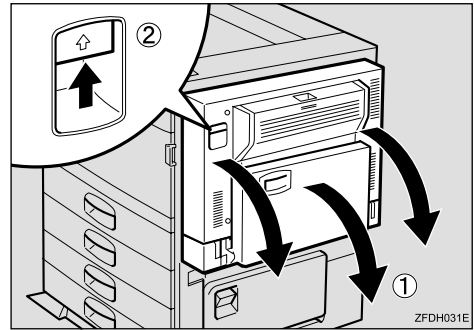

- 2 Open the right cover by pushing the catch upwards.

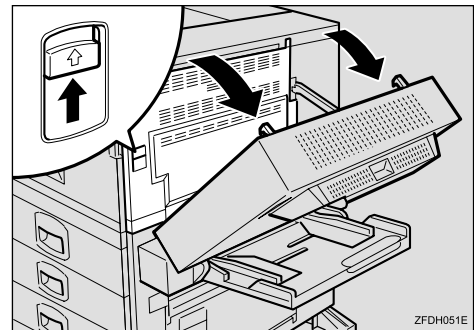

📎 Note

- ❑ If the optional Large Capacity Tray RT36 is equipped with your printer, pull the lever (①) to extend the connecting unit (②).

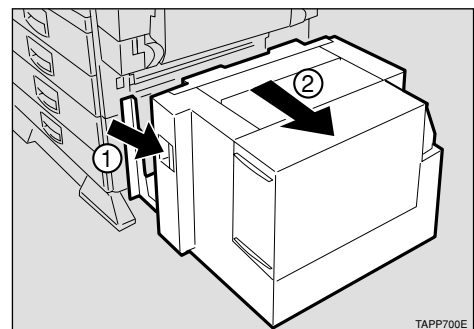

- 3** Open the lower vertical paper feed cover.

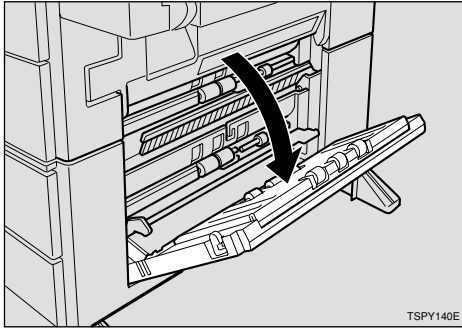

- 4** Remove the misfed paper.

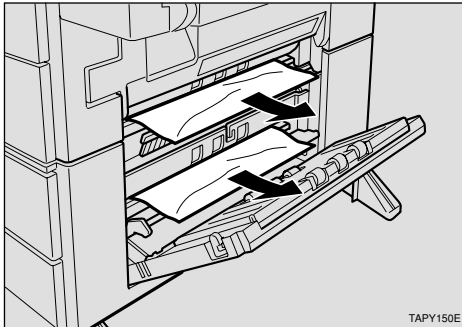

- 5** Close the lower vertical paper feed cover.

- 6** Open the upper vertical paper feed cover.

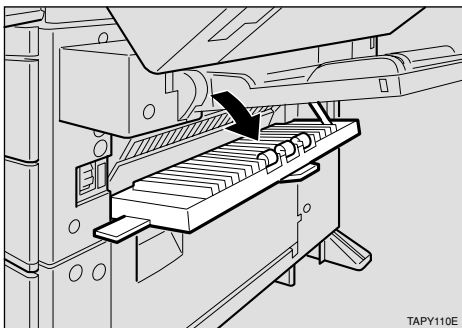

Note

- If your printer is equipped with the optional Large Capacity Tray RT36, the upper vertical paper feed cover is removed.

- 7** Turn the blue knob A1 downwards.

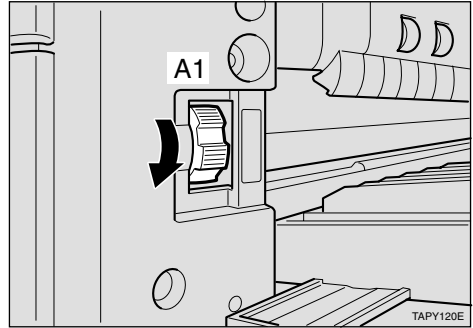

- 8** While lifting the blue lever A2 in the right cover (①), remove the misfed paper (②).

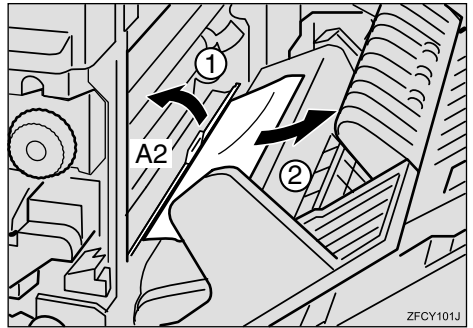

- 9** Open the Bypass Tray, and then remove the misfed paper.

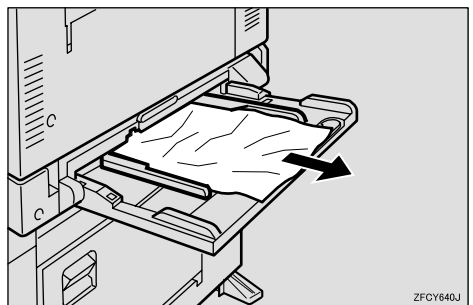

- 10** Close the covers in the following order:

- The upper vertical paper feed cover
- The right cover
- The Duplex Unit
- The Bypass Tray

When "Remove Misfeed B,C,D:Internal" Appears

- 1 Open the output feeder cover of the Bridge Unit (①), and then remove the misfed paper (②).

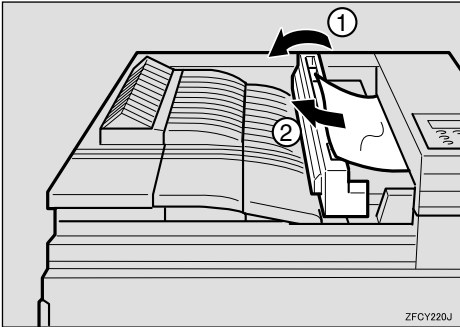

5

- 2 Open the Bypass Tray (①), and then open the Duplex Unit by pushing the catch upwards (②).

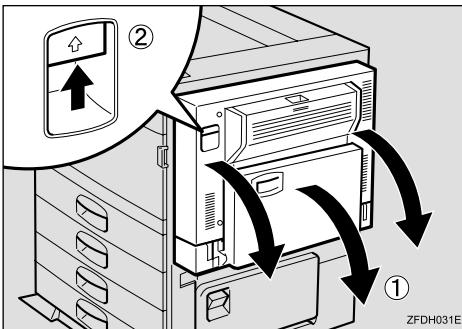

- 3 Open the right cover by pushing the catch upwards.

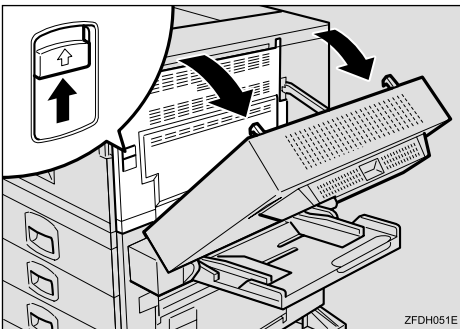

- 4 Open the front cover.

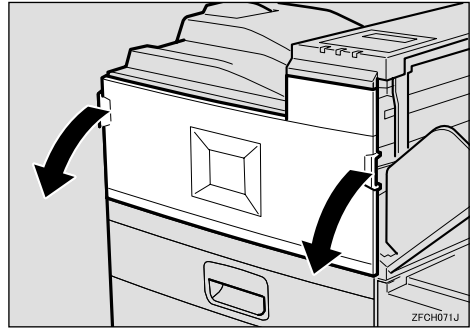

- 5 Remove the misfed paper by turning the blue knob C as shown in the illustration.

If you turn the blue knob C clockwise (①), the misfed paper comes out to the output tray (②).

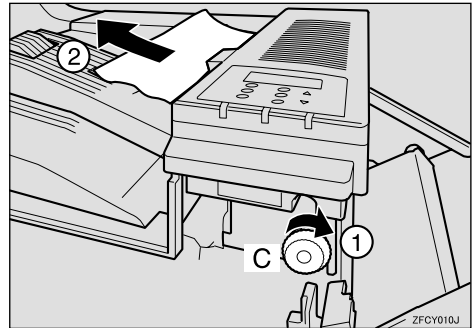

If you turn the blue knob C counterclockwise (①), remove the misfed paper from inside the right cover (②).

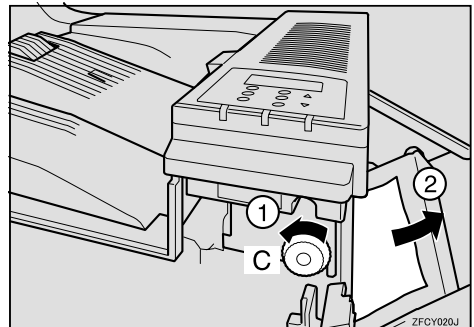

- 6** If you can see the paper from the right of the printer, remove it.

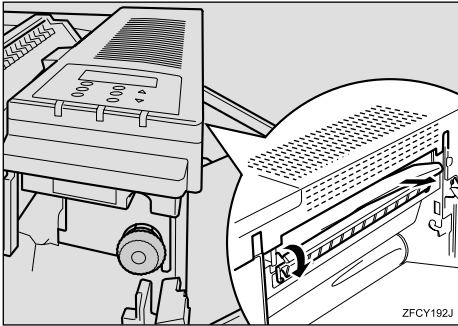

- 7** Turn the blue knob B counter-clockwise (①), and then remove the misfed paper from inside the right cover (②).

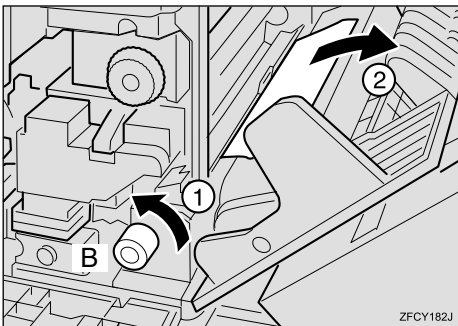

- 8** Close the covers in the following order:

- The right cover
- The Duplex Unit
- The Bypass Tray
- The front cover
- The output feeder cover

- 9** Open the covers of the Bridge Unit (①), and then remove the misfed paper (②).

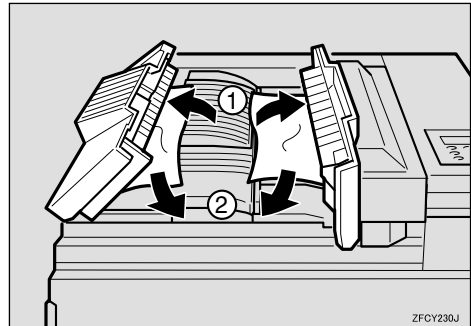

- 10** Close the cover of the Bridge Unit.

When "Remove Misfed R:Finisher" Appears

Finisher SR720

- 1 Remove the misfed paper from the output tray of the Finisher SR720.

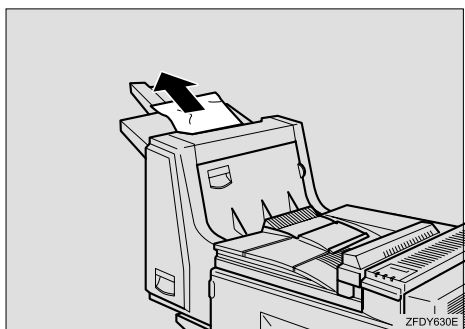

- 2 If you cannot remove the misfed paper in step 1, open the right cover of the Finisher SR720.

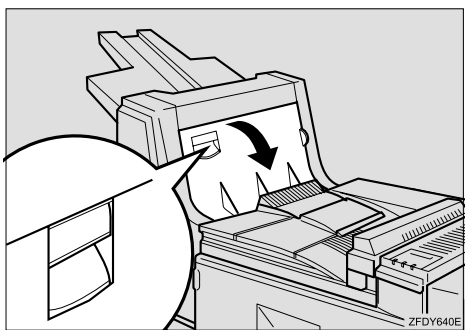

- 3 Remove the misfed paper.

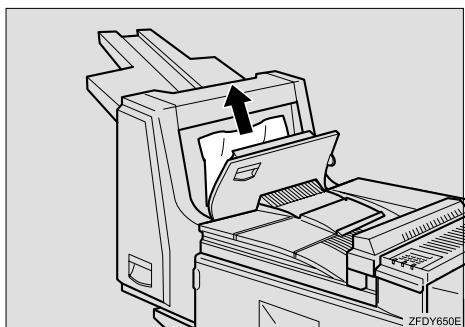

- 4 Close the right cover of the Finisher SR720.

- 5 If you cannot remove the misfed paper in step 3, slide the stack unit of the Finisher SR720 out (1), and then remove the misfed paper (2).

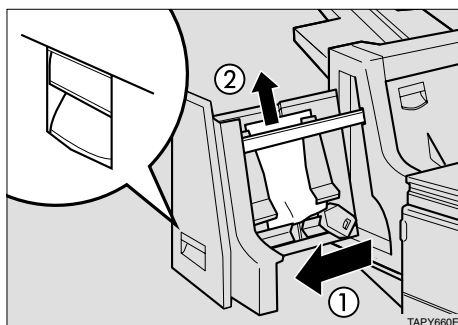

- 6 Slide the stack unit into the Finisher SR720 until it stops.

Finisher SR730

- 1 Open the front cover of the Finisher SR730.

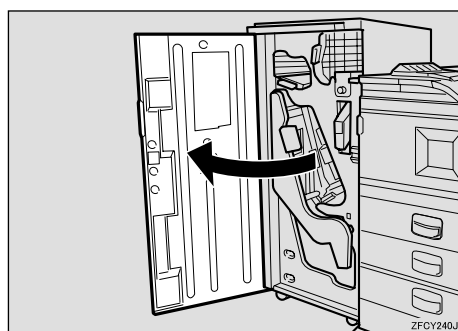

- 2** While pushing the blue lever R1 upwards (①), remove the misfed paper (②).

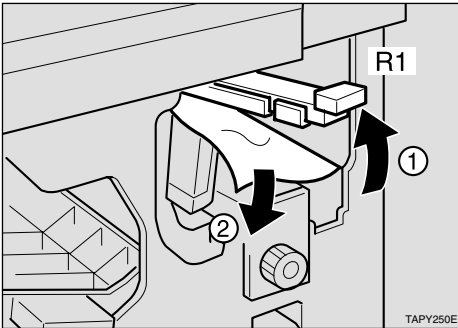

- 5** Push the lever R4 to the left (①), and then remove the misfed paper (②).

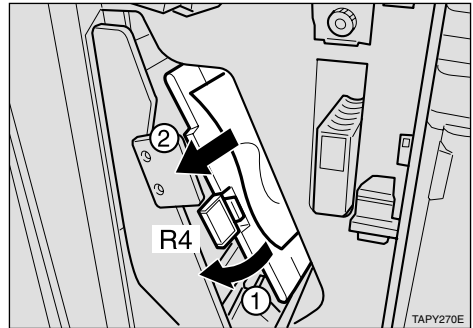

- 3** If you cannot remove the misfed paper in step 2, remove the misfed paper (①) while pushing the blue lever R2 downwards in a clockwise direction (②).



- 6** Return the blue lever R4 to its original position.

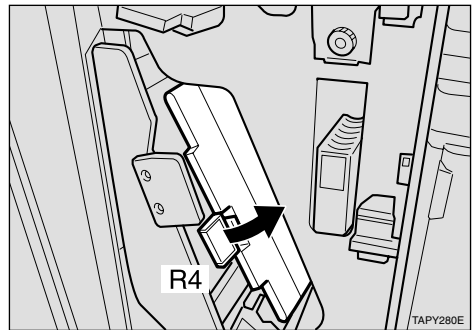

5

- 4** While pushing the blue lever R3 upwards in a clockwise direction (①), remove the misfed paper (②).



- 7** If you cannot remove the misfed paper in step 6, remove it (②) while pushing the blue lever R5 upwards in a clockwise direction (①).

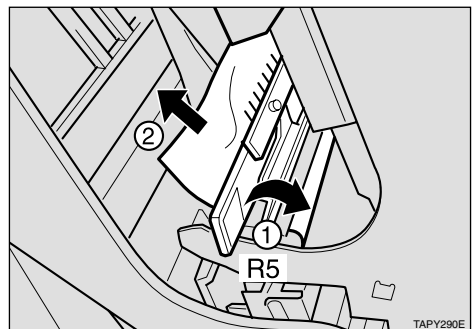

- 8** Hold the blue lever R6 and pull out the stack unit (①), and then remove the misfed paper (②).

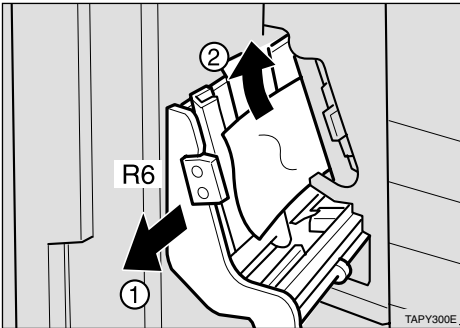

- 9** Return the stack unit to its original position (①), and then close the front cover of the Finisher SR730 (②).

5

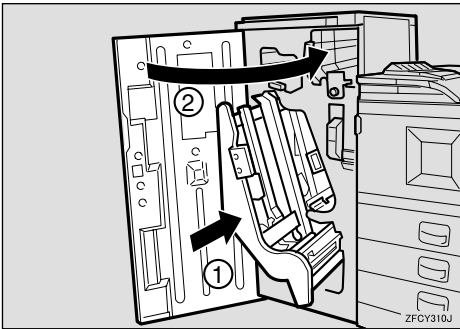

When "Remove Misfeed U:LCT" Appears

- 1** Open the top cover of the Large Capacity Tray RT36.

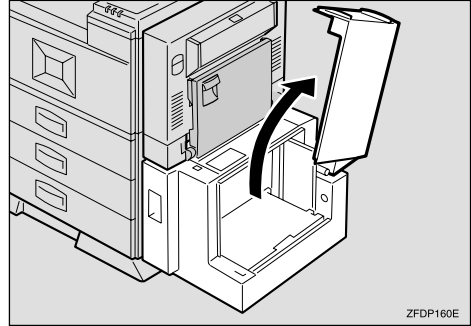

- 2** Remove the misfed paper.

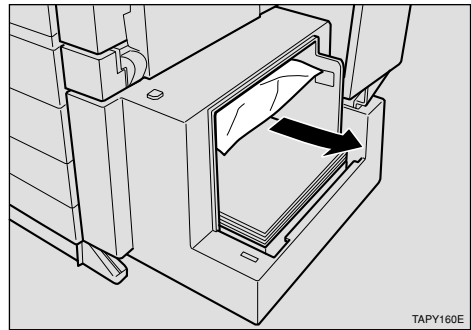

- 3** If you cannot remove the misfed paper in step 2, close the top cover of the Large Capacity Tray RT36 and pull the lever (①) to extend the connecting unit (②).

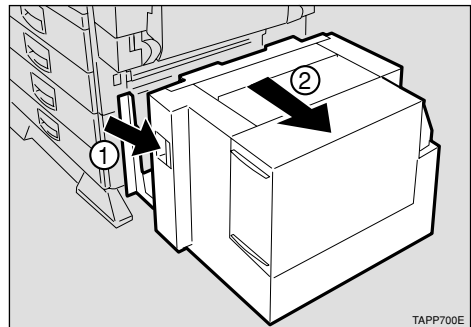

- 4 Remove the misfed paper from the left side of the Large Capacity Tray RT36.

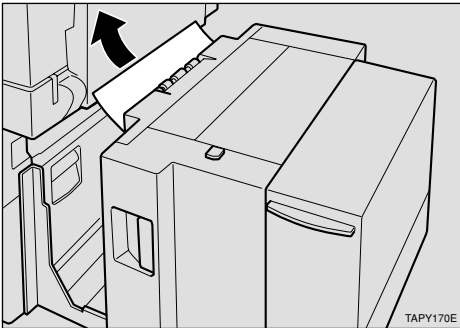

- 5 Slide the Large Capacity Tray RT36 forward to connect it to the printer.

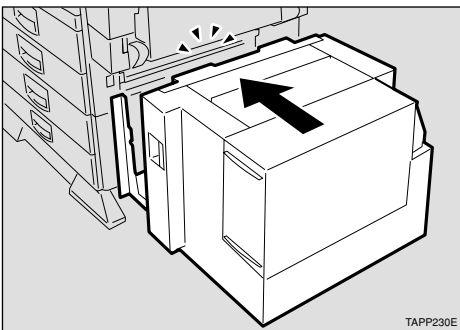

When "Remove Misfeed W:Mailbox" Appears

- 1 Open the front cover of the Mailbox CS360.

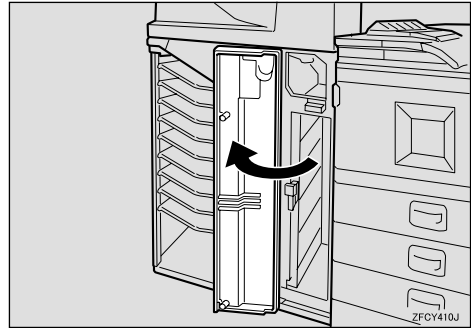

- 2 Push the blue lever W1 downwards to open the cover inside (1). Then remove the misfed paper (2).

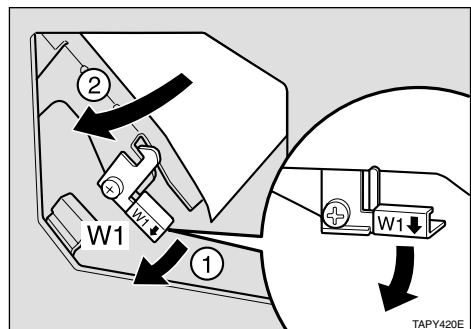

- 3 While pushing the blue lever W1 downwards, return the cover to its original position.

5

- 4** While opening the W2 cover (①), remove the misfed paper (②).

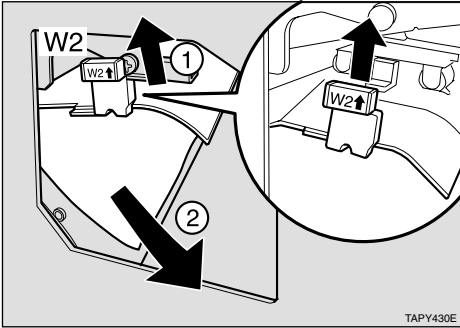

- 5** Push the blue button W3 to open the cover (①), and then remove the misfed paper (②).

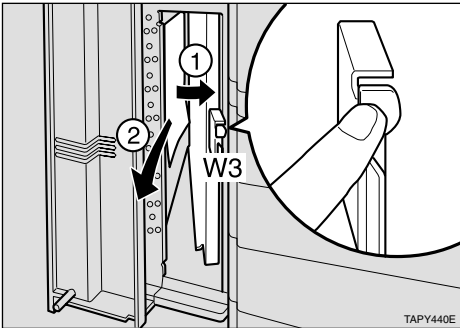

- 6** Close the cover and press it down until it clicks into place.

- 7** Open the top cover of the Mailbox CS360.

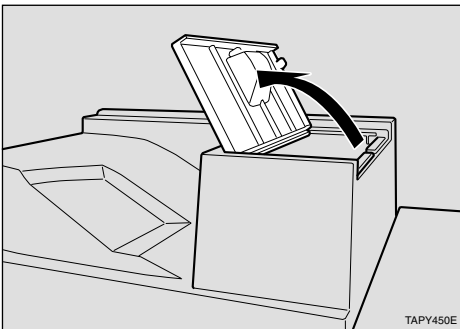

- 8** Pull the blue lever W5 to the right to open the cover (①), and then remove the misfed paper (②).

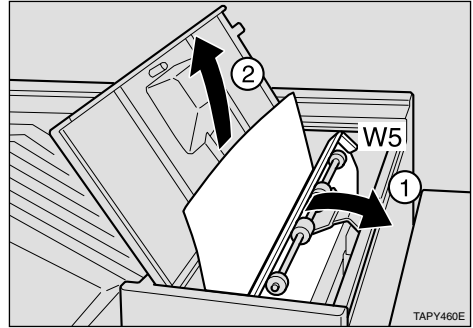

- 9** Return the cover to its original position.

- 10** While pulling the blue lever W6 upwards (①), remove the misfed paper (②).

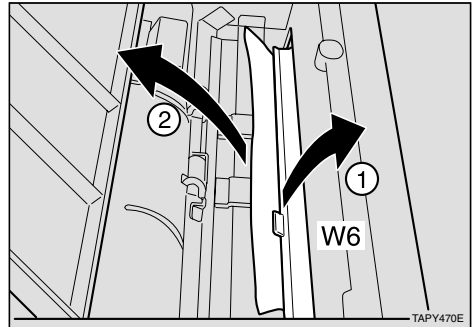

- 11** Remove the misfed paper from the output tray.

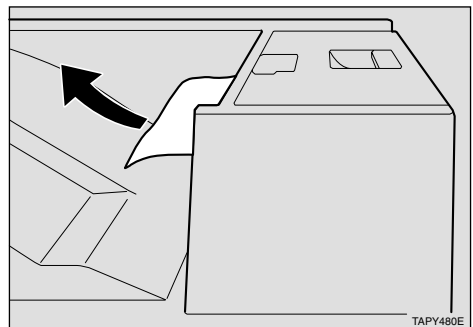

- 12** If your printer is equipped with both the Finisher SR730 and the Mailbox CS360, open the triangular cover on the front of the Mailbox CS360.

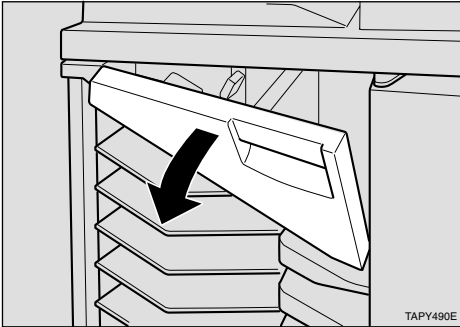

- 13** Turn the blue lever W4 counter-clockwise to open the cover (1), and then remove the misfed paper (2).

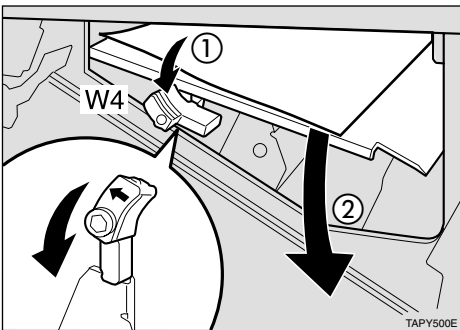

- 14** Turn the blue lever W4 clockwise to return the cover to its original position.

- 15** Close the triangular cover and the front cover of the Mailbox CS360.

When "Remove Misfeed Z:Duplex Unit" Appears

- 1** Open the Bypass Tray and the Duplex Unit right cover, and then remove the misfed paper.

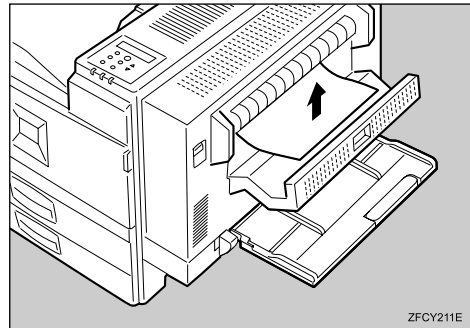

- 2** Close the Duplex Unit right cover.

- 3** Open the Duplex Unit by pushing the catch upwards (1).

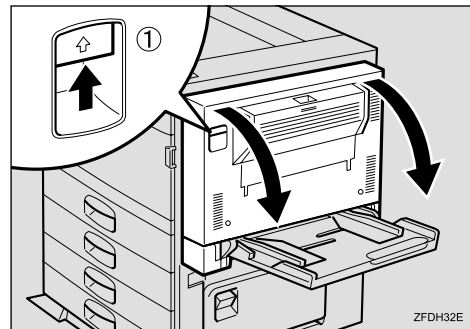

- 4** Open the cover Z to the left (①), and then remove the misfed paper (②).

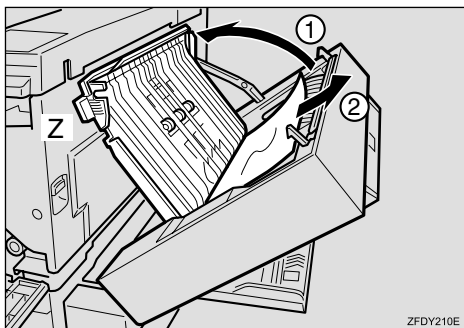

- 5** Close the covers in the following order:

- The cover Z
- The Duplex Unit
- The Bypass Tray

5

Adding Staples

When “Add Staples” appears on the panel display, the staples are almost empty. Follow these steps to replace the staple refill with a new one.

Note

- ❑ After adding the staple refill, staples might not be ejected for the first few times.

Finisher SR720

- 1** Slide the stack unit of the Finisher SR720 out until it stops.

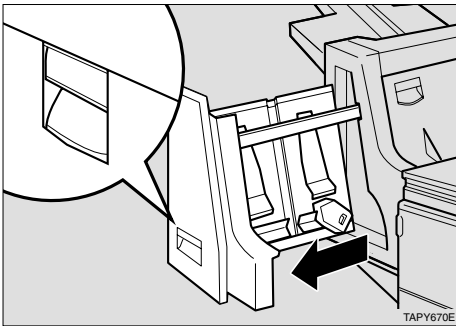

- 2** Remove the staple cartridge.

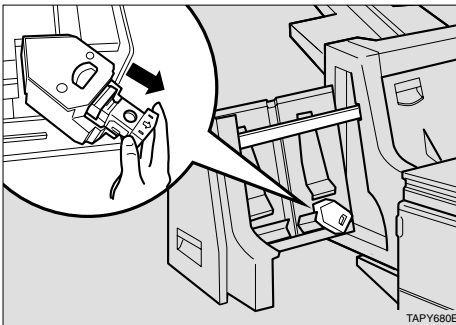

- 3** Remove the empty refill case (white).

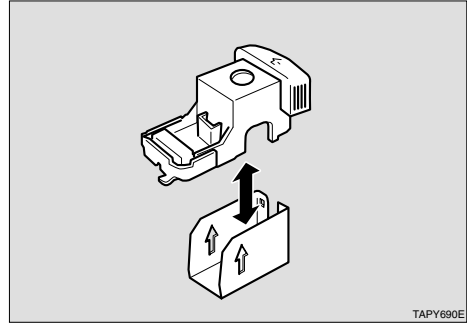

- 4** Add a new refill and align the arrows on the refill case and the cartridge, and then push the refill case in until it clicks.

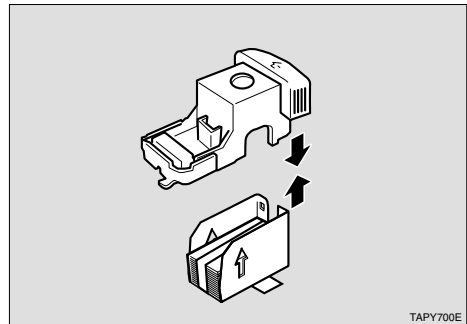

- 5** Pull out the ribbon from the bottom of the refill case.

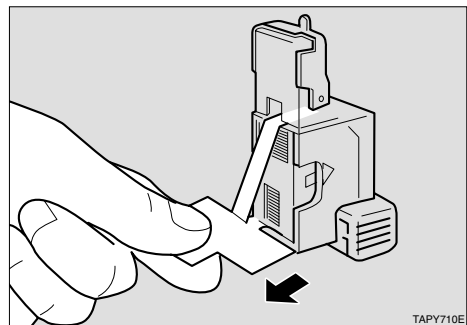

- 6** Slide the cartridge in until it clicks.

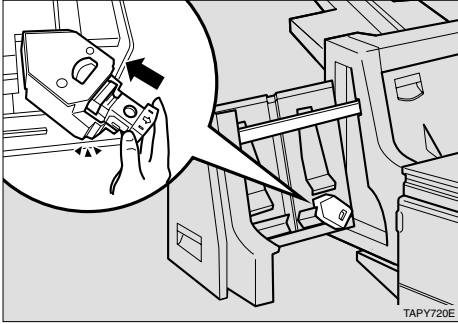

- 3** Remove the empty refill case (white).

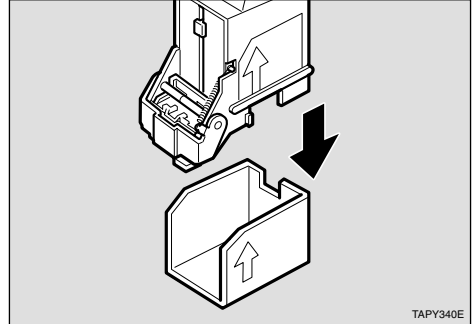

- 7** Slide the stack unit into the Finisher SR720.

- 4** Add a new refill and align the arrows on the refill case and the cartridge, and then push the refill case in until it clicks.

5

Finisher SR730

- 1** Open the front cover of the Finisher SR730 (①), and then slide the stack unit out until it stops (②).

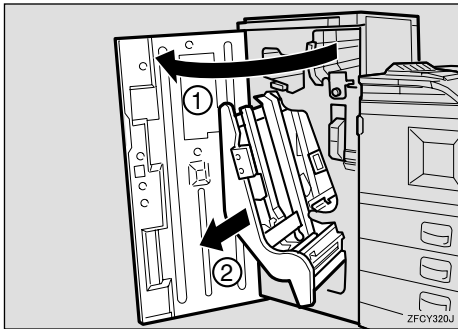
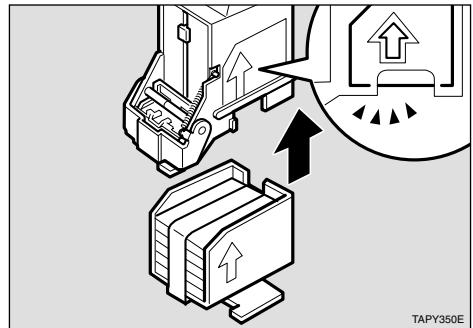

- 5** Pull out the ribbon from the bottom of the refill case.

- 2** Lift the staple cartridge until it clicks, and then remove the cartridge carefully.

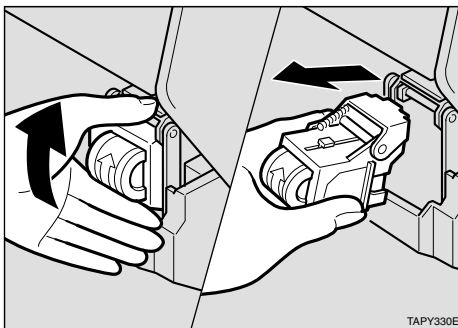
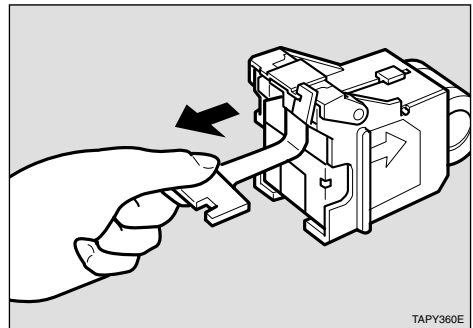

- 6** Reinstall the cartridge, and press down on the cartridge until it clicks into place.

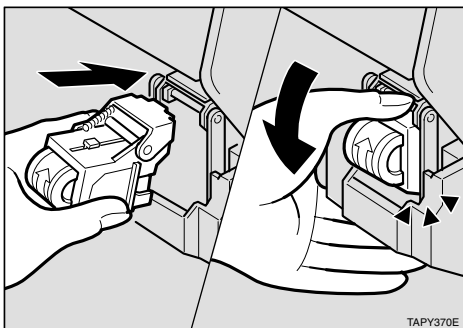

- 7** Slide the stack unit into the Finisher SR730 (①), and then close the cover (②).

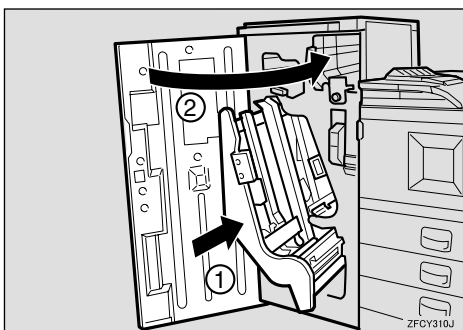

Removing Jammed Staples

If staples do not eject properly, they might be jammed.

Note

- ❑ Staples might be jammed because of curled paper. In this case, try turning the paper over in the tray.
- ❑ After removing the jammed staples, staples might not be ejected for the first few times.

3 Open the face plate.

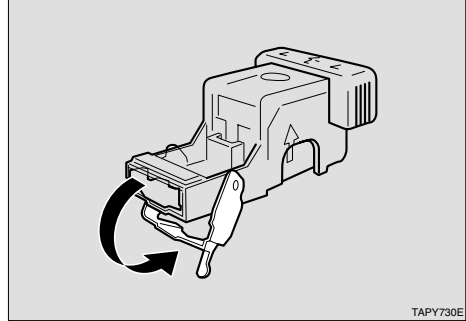

4 Remove the jammed staples.

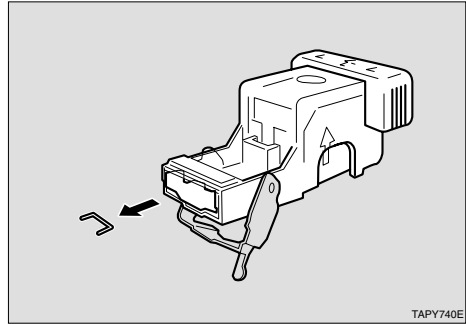

5 Close the face plate.

6 Slide the staple cartridge in until it clicks.

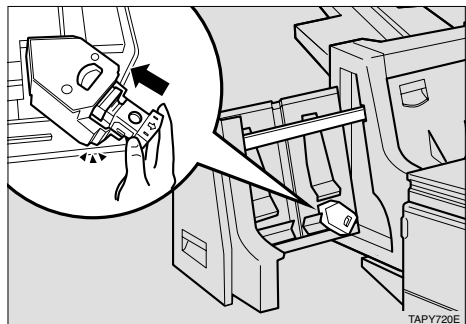

7 Slide the stack unit into the Finisher SR720.

Finisher SR720

5

1 Slide the stack unit of the Finisher SR720 out until it stops.

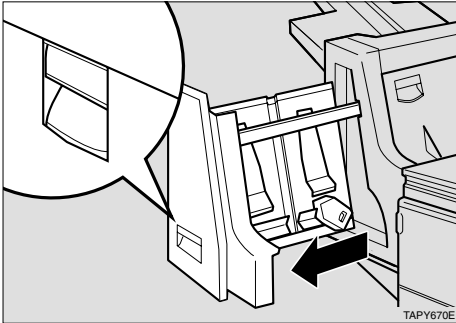

2 Remove the staple cartridge.

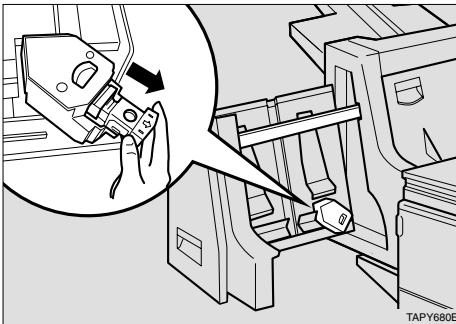

Finisher SR730

- 1 Open the front cover of the Finisher SR730 (①), and then slide the stack unit out until it stops (②).

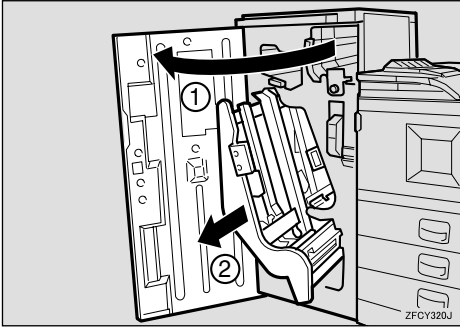

- 2 Lift the staple cartridge until it clicks, and then remove the cartridge carefully.

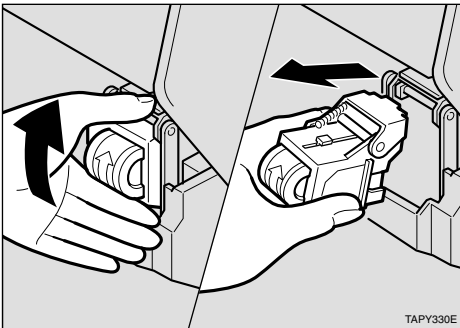

- 3 Press the face plate lock down to open the face plate.

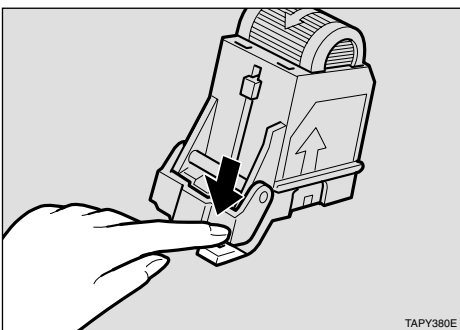

- 4 Remove the jammed staples.

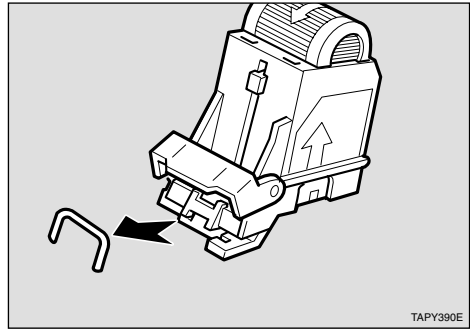

- 5 Close the face plate by pressing it down until it clicks into place.

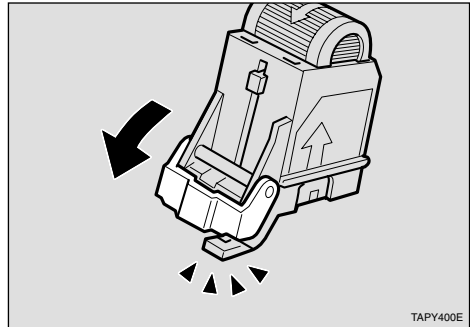

- 6 Reinstall the cartridge, and then press the cartridge down until it clicks into place.

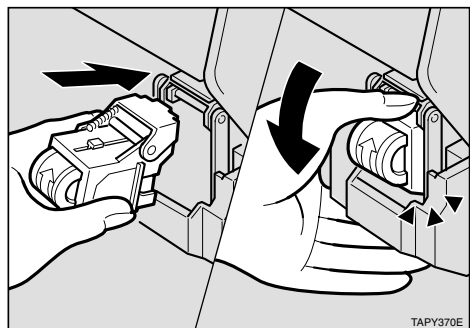

- 7** Slide the stack unit into the Finisher SR730 (①), and close the cover (②).

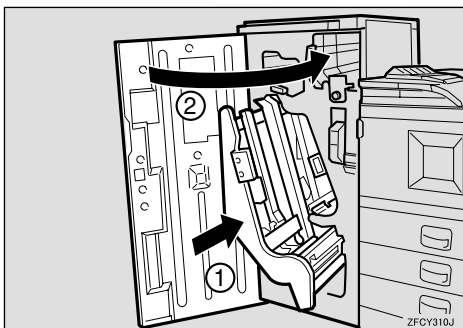



Replacing the Toner Bottle

⚠️ WARNING:

- **Do not incinerate toner (used or unused) or toner containers. Toner dust is flammable and might ignite when exposed to an open flame.**
- **Disposal should take place at an authorized dealer or appropriate collection site.**
- **If you dispose of the used toner containers yourself, follow local regulations.**

⚠️ CAUTION:

- *The inside of the machine becomes very hot. Do not touch the parts with a label indicating "⚠️" (means hot surface). Touching "⚠️" (means hot surface) could result in a burn.*
- *Do not eat or swallow toner.*
- *Keep toner (used or unused) and toner containers out of reach of children.*
- *Our products are engineered to meet the highest standards of quality and functionality. When purchasing expendable supplies, we recommend using only those specified by an authorized dealer.*

When "Toner is Almost Empty" appears on the panel display, the toner is almost empty. Prepare a new toner bottle. If the image density is too light, replace the old toner bottle with a new one.

When "Replace Toner Bottle" appears on the panel display, the toner bottle is empty. Prepare a new toner bottle and replace the old toner bottle with a new one.

📝 Note

- ❑ The actual number of printed pages you get from a particular toner bottle depends on the type and size of paper you are using, the contents of your print images, and printing environment conditions.

1 Open the front cover.

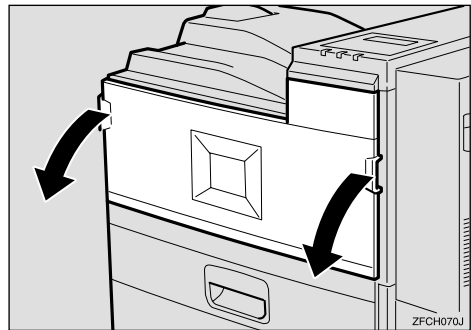

2 Remove the tape on the development unit.

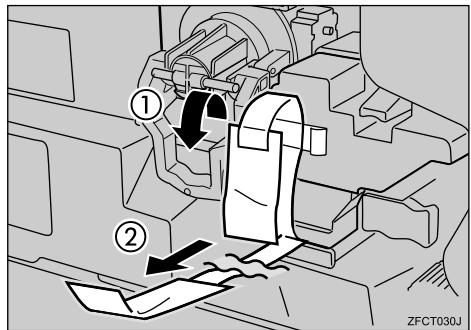

3 Lift the green handle.

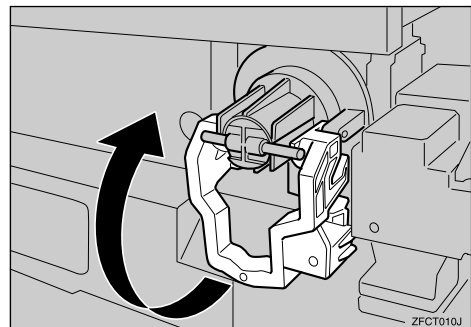

- 4** While pushing the green lever to the right (①), hold the handle and gently slide the toner holder out (②).

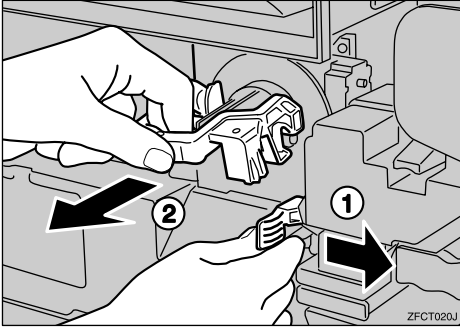

- 7** Place the toner bottle on the toner holder (①), and then pull its head toward you (②) to lock it in place.

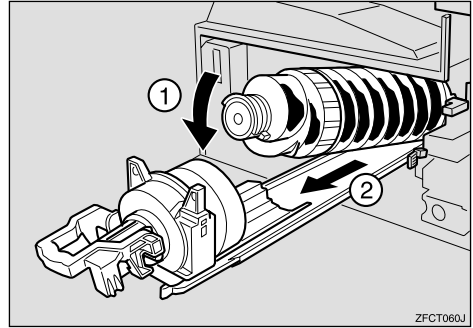

- 5** Shake the new toner bottle back and forth about 5 - 6 times as shown in the illustration.

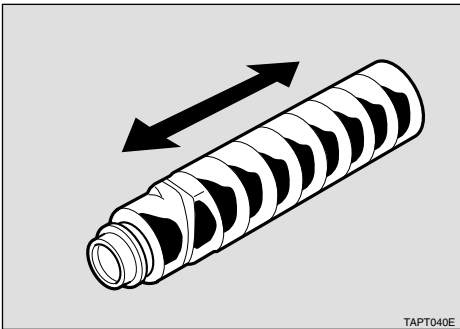

- 8** Slide the toner holder into the printer until it clicks into place, and then push down on the green handle.

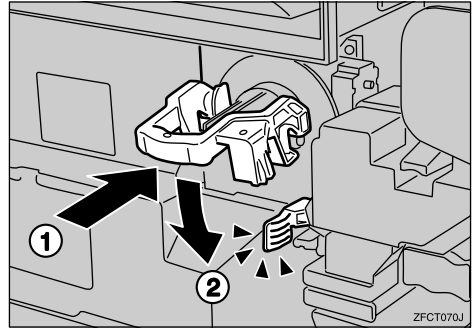

- 6** Remove the black cap of the new toner bottle by turning it counter-clockwise.

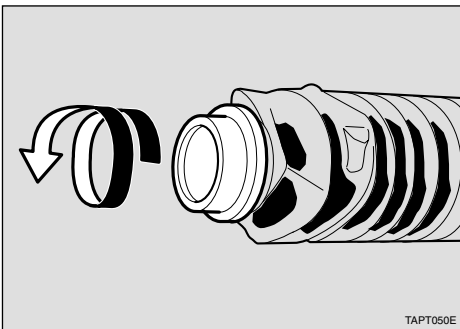

- 9** Close the front cover.

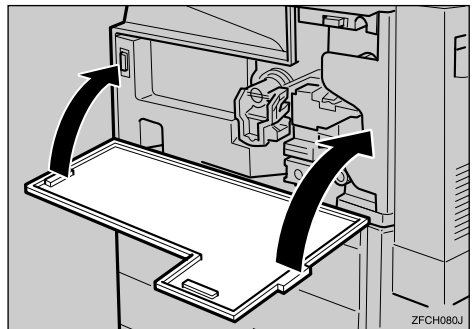

Note

- ❑ After removing the black cap from the bottle, toner can scatter easily. Do not shake or jar the bottle.

6. Making Printer Settings with the Control Panel

Menu Chart

This section describes how to change the default settings of the printer and provides information on the parameters included in each menu.

Category	Function menu	
Counter	Show Counter	
	Print	
Sample Print *1 ⇒ p.45	Print File / Delete File / Error File(s)	
Locked Print *1 ⇒ p.49	Print File / Delete File / Error File(s)	
Paper Input⇒ p.104	Bypass Size	
	Tray Paper Size	
	Paper Type	
	Tray Locking	
	Tray Priority	
List/Test Print⇒ p.108	Config. Page	
	Menu List	
	PS Config. Page	
	PCL Config. Page	
	Hex Dump	
Maintenance⇒ p.112	Image Density	
	Registration	Prt. Test Sheet
		Adjustment
	HDD Format	
	Menu Protect *2	

Category	Function menu	
System⇒ p.116	MisfeedRecovery	
	Prt. Err Report	
	Auto Continue	
	Memory Overflow	
	Sub Paper Size	
	Page Size	
	Duplex	
	Output Tray	
	Job Separation	
	Energy Saver	
	Memory Usage	
	Unit Of Measure	
	Edge Smoothing	
	Resolution	PCL
		PS
TIFF		
Toner Saving		
Spool Printing		
Host Interface⇒ p.122	I/O Buffer	
	I/O Timeout	
	Network Setup	IP Address
		Subnet Mask
		Gateway Address
		Network Boot
		Frame Type (NW)
		Active Protocol
	Ethernet	
	IEEE 1394 Setup	IP Address1394
		Subnet Mask1394
		IP over 1394
SCSI print		

Category	Function menu
PCL Menu⇒ p.127	Orientation
	Form Lines
	Font Source
	Font Number
	Point Size
	Font Pitch
	Symbol Set
Language⇒ p.130	

*1 The “Sample Print” menu and the “Locked Print” menu appear only when the optional Printer Hard Disk is installed.

*2 While the printer is **On Line**, press **【Enter #】**, and then press **【Escape】**, finally press **【Menu】**. You can access the “Menu Protect ” on the panel display.

Accessing the Main Menu

Press **[Menu]**, and “Menu” appears on the panel display.

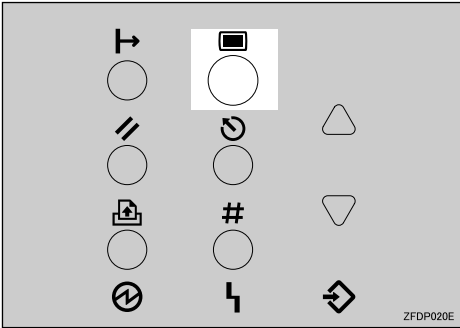

This menu shows the following nine items which can be displayed one by one pressing **[▲]** or **[▼]**.

- Counter
- Sample Print
- Locked Print
- Paper Input
- List/Test Print
- Maintenance
- System
- Host Interface
- PCL Menu
- Language

Note

- If the optional Printer Hard Disk is not installed, the “Sample Print” menu and the “Locked print” menu cannot be displayed on the control panel.
- [▼]**: Press to go to the next page.
- [▲]**: Press to go back to the previous page.
- After making the printer settings, be sure to return to the previous menu by pressing **[Escape]**.

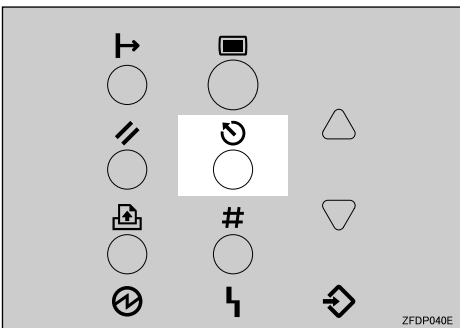

- ❑ After making the printer settings, press **[On Line]** to return to the “Ready” condition.

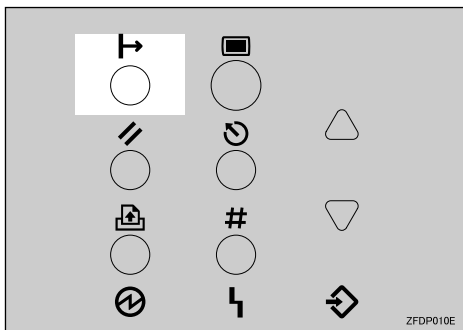

- ❑ The revised settings are not canceled even if the power switch is turned off.

Paper Input Menu

There are five menu items in the “Paper Input” menu.



- Bypass Size
- Tray Paper Size
- Paper Type
- Tray Locking
- Tray Priority

Reference

For more information about loading paper in the tray, see p.33 “Loading Paper and Other Media”.

Paper Input Parameters

Menu	Description
Bypass Size	<p>The paper size for the Bypass Tray.</p> <p>For more information about paper sizes that can be set in the Bypass Tray, see p.25 “Paper and Other Media Supported by This Printer”.</p>
Tray Paper Size	<p>The paper size for each tray.</p> <p>When you select the sizes that are not indicated on the paper size dial of Tray 1, Tray 2 or Tray 3, you should set the dial to “✱” and then select the paper size here.</p> <p>❖ Tray 1 For more information about paper sizes that can be set in the Tray 1, see p.25 “Paper and Other Media Supported by This Printer”.</p> <p>❖ Tray 2 For more information about paper sizes that can be set in the Tray 2, see p.25 “Paper and Other Media Supported by This Printer”.</p> <p>❖ Tray 3 For more information about paper sizes that can be set in the Tray 3, see p.25 “Paper and Other Media Supported by This Printer”.</p> <p>❖ Tray 4 For more information about paper sizes that can be set in the Tray 4, see p.25 “Paper and Other Media Supported by This Printer”.</p> <p> Note <input type="checkbox"/> Only the installed trays appear on the panel display.</p>

Menu	Description
Paper type	<p>If you use different kinds of paper, you set the paper type for Tray 1, Tray 2, Tray 3, Tray 4, Large Capacity Tray or Bypass Tray.</p> <p>❖ Tray 1, Tray 2, Tray 3, Tray 4, LCT Plain Paper, Recycled Paper, Special Paper, Color Paper, Letterhead, Preprinted, Prepunched, Bond paper, Cardstock</p> <p>❖ Bypass Tray Plain Paper, Recycled Paper, Special Paper, Color Paper, Letterhead, Preprinted, Prepunched, Labels, Bond paper, Cardstock, Transparency, Thick Paper</p> <p> Note</p> <ul style="list-style-type: none"> <input type="checkbox"/> Default : Plain Paper <input type="checkbox"/> Only the installed trays appear on the panel display.
Tray Locking	<p>If you use different kinds of paper, you can lock a tray to prevent printing on wrong paper such as letterhead or colored paper. When "Auto Select" is selected in the Paper Source selections from the printer driver, the locked tray will not be used.</p> <p>Tray 1, Tray 2, Tray 3, Tray 4, LCT, Bypass Tray</p> <p> Note</p> <ul style="list-style-type: none"> <input type="checkbox"/> Only the installed trays appear on the panel display. <input type="checkbox"/> You cannot lock multiple trays. <input type="checkbox"/> If you want to use the locked tray, you must select the tray from the printer driver. <input type="checkbox"/> When a locked tray is selected from the printer driver, the printer does not search for another tray.
Tray Priority	<p>You can set which tray should be checked first when "Auto Tray Select" is selected in the Paper Source selections from the printer driver. When printing from DOS, the tray selected here is used when no tray is selected for a print job.</p> <p>Tray 1, Tray 2, Tray 3, Tray 4, LCT</p> <p> Note</p> <ul style="list-style-type: none"> <input type="checkbox"/> Default : Tray 1 <input type="checkbox"/> Only the installed trays appear on the panel display. <input type="checkbox"/> It is recommended that you load paper of the size and direction you most frequently use in the tray selected with "Tray Priority".

Changing the Paper Input Menu

- 1 Press [Menu].

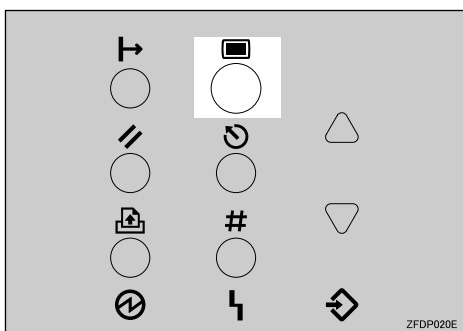

“Menu” appears on the panel display.

- 2 Press [▲] or [▼] to display the “Paper Input” menu.

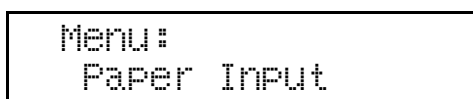

- 3 Press [Enter #].

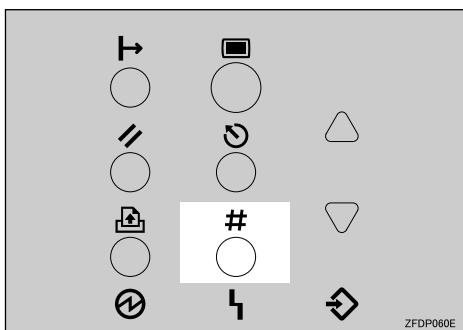

- 4 Press [▲] or [▼] to display “Tray Priority”.



- 5 Press [Enter #].

The following message appears on the panel display.

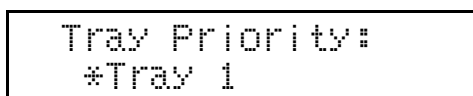

- 6 Press [▲] or [▼] to select the tray type you want to use.

7 Press **[Enter #]**. Wait for two seconds.

“Menu” appears on the panel display.

8 Press **[On Line]**.

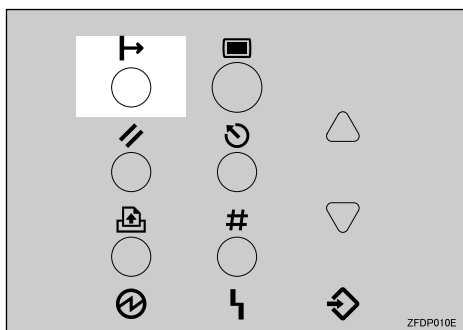

“Ready” appears on the panel display.



List/Test Print Menu

There are five menu items in the “List/Test Print” menu.

- Config. Page
- Menu List
- PS Config. Page
- PCL Config. Page
- Hex Dump

List/Test Print Parameters

Menu	Description
Config. Page	You can print the current configuration of the printer. See p.108 “Printing a Configuration Page”.
Menu List	You can print the Menu List which shows the function menus of this printer.
PS Config. Page	You can print the current configuration of the PostScript.
PCL Config. Page	You can print the current configuration of the PCL.
Hex Dump	You can print the Hex Dump.

6

Printing a Configuration Page

Reference

For more information, see p.110 “Interpreting the Configuration Page”.

1 Press **[Menu]**.

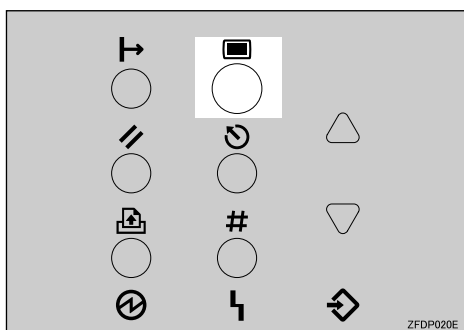

“Menu” appears on the panel display.

2 Press **[▼]** or **[▲]** to display “List/Test Print” menu.

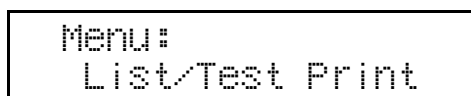

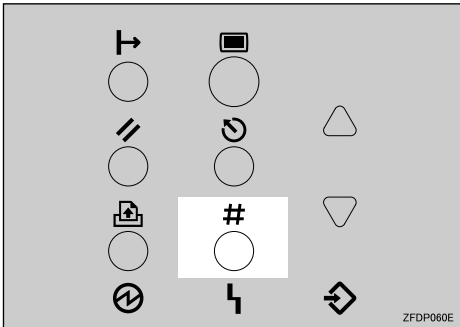
3 Press **[Enter #]**.

The following message appears on the panel display.

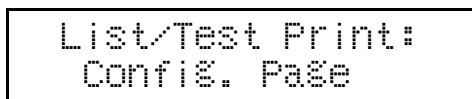
**4** Press **[Enter #]**.

The following message appears on the panel display.

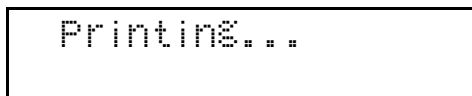

In a short time, the printing a configuration page will start.

Important

- If you cannot print a configuration page correctly, check for an error message on the panel display. For more information about error messages, see p.55 "Error & Status Messages on the Control Panel".

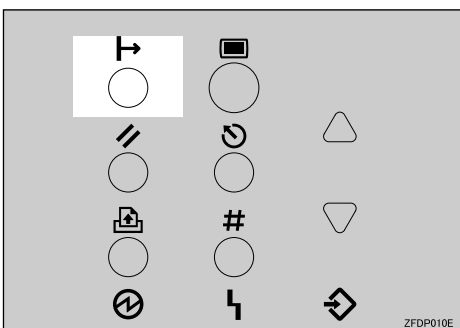
5 Press **[On Line]**.

"Ready" appears on the panel display.

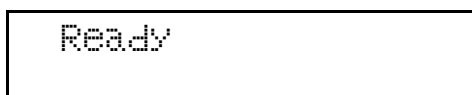

Interpreting the Configuration Page

System Reference

- ❖ **Printer ID**
Shows the serial number assigned to the board by its manufacturer.
- ❖ **Firmware Version**
Shows the version number of the printer firmware.
- ❖ **NCS Version**
Shows the version of the Network Interface Board.
- ❖ **IEEE1394**
Shows if the optional IEEE1394 board is installed.
- ❖ **Printer Language**
Shows the version number of the printer driver language.
- ❖ **Options**
Shows the optional trays that you installed.
- ❖ **Pages Printed**
Shows the total number of pages printed by the printer to date.
- ❖ **Engine version**
Shows the version number of the printer engine.
- ❖ **Total Memory**
Shows the total amount of memory (SDRAM) installed on the printer.
- ❖ **Printer Hard Disk**
Shows if the optional Printer Hard Disk is installed.

Paper Input

Shows the settings made under the “Paper Input” menu.

 **Reference**

For more information, see p.104 “Paper Input Menu”.

System

Shows the settings made under the “System” menu.

 **Reference**

For more information, see p.116 “System Menu”.

PCL Menu

Shows the settings you made under the “PCL Menu”.

 **Reference**

For more information, see p.127 “PCL Menu”.

Host Interface

Shows the settings you made under the “Host Interface” menu.

When DHCP is active on the network, the actual IP Address, Subnet Mask and Gateway Address appear in parentheses on the configuration page.

 **Reference**

For more information about “Host Interface” menu, see p.122 “Host Interface Menu”.

Error Log

Shows the log of printer errors.

Maintenance Menu



There are four menu items in the “Maintenance” menu.

- Image Density
- Registration
- HDD Format
- Menu Protect

Note

- This “HDD Format” appears only when the Printer Hard Disk is installed. For more information, see “*Installing the Printer Hard Disk Type 4510*” in the Setup Guide.

Maintenance Menu Parameters

Menu	Description
Image Density	You can select the print image density. -3 to 3
Registration	<p>❖ Prt. Test Sheet You can print the registration test sheet. Tray 1, Tray 2, Tray 3, Tray 4, LCT, Bypass Tray</p> <p> Note</p> <ul style="list-style-type: none"> <input type="checkbox"/> Default : Tray 1 <input type="checkbox"/> Only the installed trays appear on the panel display. <p>❖ Adjustment You can select the start position for printing on page. Vertical Tray 1, Vertical Tray 2, Vertical Tray 3, Vertical Tray 4, Vertical LCT, Vertical Bypass, Vertical Duplex-back, Horizontal All Trays, Horizontal Duplex-back -4 to 4</p> <p> Note</p> <ul style="list-style-type: none"> <input type="checkbox"/> The registration value are not default. <input type="checkbox"/> Only the installed trays appear on the panel display.
HDD Format	<p>After installing the Printer Hard Disk, format it.</p> <p> Reference For more information about formatting the Printer Hard Disk, see “<i>Installing the Printer Hard Disk Type 4510</i>” in the Setup Guide.</p>

Menu	Description
Menu Protect	<p>This procedure lets you protect menu settings against accidental changes. It makes it impossible to change the menu settings you make with the normal procedure unless you perform the required key operation. In a network environment, protecting settings restricts changes to menu settings to network administrators.</p> <ul style="list-style-type: none"> • Level 1 • Level 2 • Off <p> Note</p> <ul style="list-style-type: none"> <input type="checkbox"/> Default: Off <input type="checkbox"/> While the printer is Online, press [Enter #], and then press [Escape], finally press [Menu]. You can access the "Menu Protect" menu on the panel display.

Changing the Maintenance Menu

Protecting menu

- 1** Check if the On Line indicator is on. If not, press **[On Line]** to enter the "Ready" condition.
- 2** Press **[Enter #]**, then **[Escape]**, and then **[Menu]**.

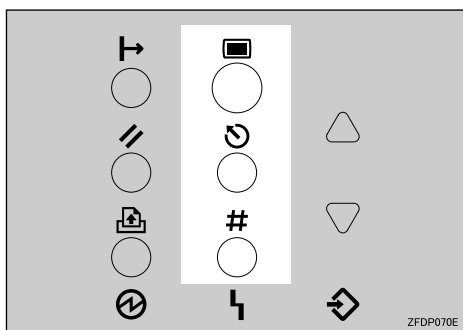

"Menu" appears on the panel display.

- 3** Press **[▲]** or **[▼]** to display the "Maintenance" menu, and then press **[Enter #]**.

The following message appears on the panel display.

```
Maintenance:
Image Density
```

- 4** Press **[▲]** or **[▼]** to display “Menu Protect”.

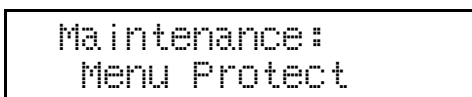

- 5** Press **[Enter #]**.

The following message appears on the panel display.

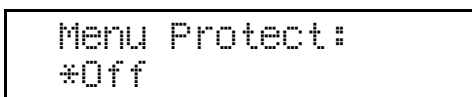

- 6** Press **[▲]** or **[▼]** to select the levels desired, and then press **[Enter #]**. Wait for two seconds.

“Menu” appears on the panel display.

- 7** Press **[On Line]**.

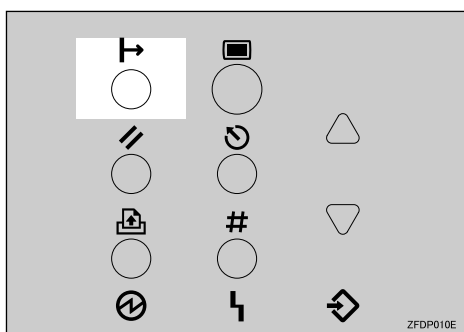

"Ready" appears on the panel display.



Cancelling the protection

- 1** Check if the On Line indicator is on. If not, press **[On Line]** to enter the "Ready" condition.

- 2** Press **[Enter #]**, then **[Escape]**, and then **[Menu]**.

“Menu” appears on the panel display.

- 3 Press **[▲]** or **[▼]** to display “Maintenance” menu, and then press **[Enter #]**.
The following message appears on the panel display.

```
Maintenance:
Image Density
```

- 4 Press **[▲]** or **[▼]** to display “Menu Protect”, and then press **[Enter #]**.
- 5 Press **[▲]** or **[▼]** to display “Off”, and then press **[Enter #]**. Wait for two seconds.
“Menu” appears on the panel display.
- 6 Press **[On Line]**.
“Ready” appears on the panel display.



System Menu





There are 16 menu items in the “System” menu.





- MisfeedRecovery
- Prt. Err Report
- Auto Continue
- Memory Overflow
- Sub Paper Size
- Page Size
- Duplex
- Output Tray
- Job Separation
- Energy Saver
- Memory Usage
- Unit Of Measure
- Edge Smoothing
- Resolution
- Toner Saving
- Spool Printing





6

System Parameters

Menu	Description
MisfeedRecovery	<p>You can select whether Misfeed Recovery is enabled. When it is on, printing restarts after the misfed paper has been cleared.</p> <ul style="list-style-type: none"> • On • Off <p> Note <input type="checkbox"/> Default: On</p>
Prt. Err Report	<p>You can select whether or not to have an error report printed when a printer error or memory error occurs.</p> <ul style="list-style-type: none"> • On • Off <p> Note <input type="checkbox"/> Default: Off</p>

Menu	Description
Auto Continue	<p>You can set whether Auto Continue is enabled. When it is on, printing continues after a system error occurs.</p> <ul style="list-style-type: none"> • Off • 0 minute • 1 minute • 5 minutes • 10 minutes • 15 minutes <p> Note</p> <ul style="list-style-type: none"> <input type="checkbox"/> Default: Off <input type="checkbox"/> When it is on, and certain types of errors occur, the current job might be canceled, and the machine automatically resumes the next job.
Memory Overflow	<p>You can select whether the memory overflow error report should be printed.</p> <ul style="list-style-type: none"> • Not Print • Error List <p> Note</p> <ul style="list-style-type: none"> <input type="checkbox"/> Default: Not Print
Sub Paper Size	<p>When "Auto" is selected, the printer selects the paper tray with paper of the specified paper size automatically.</p> <ul style="list-style-type: none"> • Off • Auto <p> Note</p> <ul style="list-style-type: none"> <input type="checkbox"/> Default: Off
Page Size	<p>You can specify the default paper size.</p> <p>11 x 17 inch <input type="checkbox"/>, legal <input type="checkbox"/>, letter <input type="checkbox"/>, 5 1/2 x 8 1/2 inch <input type="checkbox"/>, 7 1/4 x 10 1/2 inch <input type="checkbox"/>, 8 x 13 <input type="checkbox"/>, 8 1/2 x 13 <input type="checkbox"/>, 8 1/4 x 13 <input type="checkbox"/>, A3 <input type="checkbox"/>, B4 <input type="checkbox"/>, A4 <input type="checkbox"/>, B5 <input type="checkbox"/>, A5 <input type="checkbox"/>, A6 <input type="checkbox"/>, 4 1/8 x 9 1/2 <input type="checkbox"/>, 3 7/8 x 7 1/2 <input type="checkbox"/>, C5 Env <input type="checkbox"/>, C6 Env <input type="checkbox"/>, DL Env <input type="checkbox"/>, Custom Size</p> <p> Note</p> <ul style="list-style-type: none"> <input type="checkbox"/> Default: 11 x 17 <input type="checkbox"/>
Duplex	<p>You can select whether you want to print on both sides of each page.</p> <ul style="list-style-type: none"> • Off • Short Edge Bind • Long Edge Bind <p> Note</p> <ul style="list-style-type: none"> <input type="checkbox"/> Default: Off <input type="checkbox"/> This menu appears only when the Duplex Unit is installed.

Menu	Description
Output Tray	<p>You can select the default output tray. Standard Tray, Finisher Shift Tray, Finisher Proof Tray, Mailbox Proof Tray, Mailbox Tray 1-9</p> <p> Note</p> <ul style="list-style-type: none"> <input type="checkbox"/> Default: Standard Tray <input type="checkbox"/> Only the installed trays appear on the panel display.
Job Separation	<p>You can enable Job Separation.</p> <ul style="list-style-type: none"> • On • Off <p> Note</p> <ul style="list-style-type: none"> <input type="checkbox"/> Default: Off <input type="checkbox"/> This menu appears only when the optional Finisher is installed.
Energy Saver	<p>You can set how many minutes the printer waits before switching to Energy Saver mode. Energy Saver mode reduces electric power consumption.</p> <p>On, Off</p> <p>1 minute, 5 minutes, 15 minutes, 30 minutes, 45 minutes, 60 minutes,</p> <p> Note</p> <ul style="list-style-type: none"> <input type="checkbox"/> Default: On <input type="checkbox"/> Default: 1 minute <input type="checkbox"/> If there is an error in the printer, the printer will not turn into Energy Saver mode. <input type="checkbox"/> When the printer switches to Energy Saver mode, the Power indicator turns off, while the On Line indicator stays on.
Memory Usage	<p>You can select the volume of memory to be used from "Font Priority" or "Frame Priority", according to the paper size, resolution or printer language.</p> <ul style="list-style-type: none"> • Font Priority This setting uses memory for registering fonts. • Frame Priority This setting uses memory for high speed printing. <p> Note</p> <ul style="list-style-type: none"> <input type="checkbox"/> Default: Frame Priority <p> Reference</p> <p>For more information, see p.136 "Paper Size and Resolution".</p>
Unit Of Measure	<p>You can select "mm" or "inch" for the custom paper size.</p>

Menu	Description
Edge Smoothing	<p>You can set whether Edge Smoothing is enabled. When it is on, jagged lines appear more smoothly. Set it to off when the print image contains fine gradation in tone.</p> <ul style="list-style-type: none"> • On • Off <p> Note</p> <ul style="list-style-type: none"> <input type="checkbox"/> Default: Off <input type="checkbox"/> If "Toner Saving" is "On", "Edge Smoothing" is ignored even if it is "On".
Resolution	<p>You can set the print resolution in dots per inch.</p> <ul style="list-style-type: none"> ◆ PCL 300 dpi, 600 dpi ◆ PS 300 dpi, 600 dpi ◆ TIFF 200 dpi, 300 dpi, 400 dpi, 600 dpi <p> Note</p> <ul style="list-style-type: none"> <input type="checkbox"/> Default: 600 dpi
Toner Saving	<p>You can select whether or not Toner Saving is enabled.</p> <ul style="list-style-type: none"> • On • Off <p> Note</p> <ul style="list-style-type: none"> <input type="checkbox"/> Default: Off <input type="checkbox"/> If "Toner Saving" is "On", "Edge Smoothing" is ignored even if it is "On".
Spool Printing	<p>When "On" is selected, the entire print data is spooled to the Printer Hard Disk before printing.</p> <ul style="list-style-type: none"> • On • Off <p> Note</p> <ul style="list-style-type: none"> <input type="checkbox"/> Default: Off <p> Limitation</p> <ul style="list-style-type: none"> <input type="checkbox"/> "Spool Printing" does not appear unless the optional Printer Hard Disk is installed.

Changing the System Menu

1 Press [Menu].

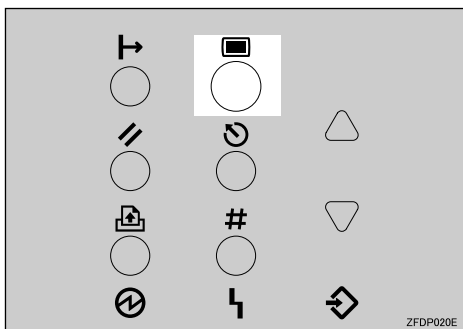

“Menu” appears on the panel display.

2 Press [▲] or [▼] to display the “System” menu.

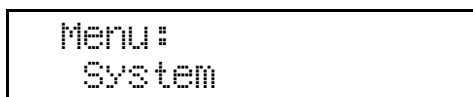

3 Press [Enter #].

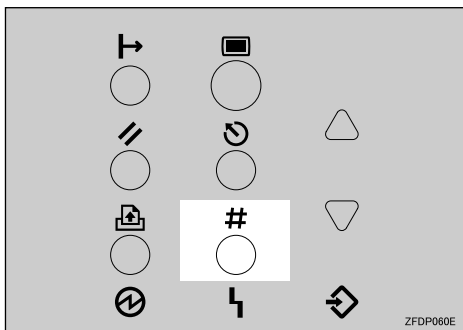

The following message appears on the panel display.

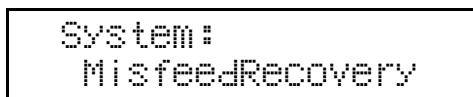

4 Press [▲] or [▼] to display “Energy Saver”.

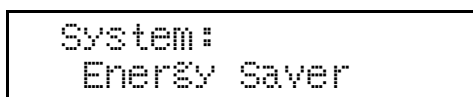

5 Press **[Enter #]**.

The following message appears on the panel display.

```
Energy Saver:
E. Saver OnOff
```

6 Press **[▲]** or **[▼]** to display "E. Saver Timer".

```
Energy Saver:
E. Saver Timer
```

7 Press **[Enter #]**.

The following message appears on the panel display.

```
Energy Saver:
*1 minute
```

8 Press **[▲]** or **[▼]** to select how many minutes the printer waits before switching to Energy Saver mode.**9** Press **[Enter #]**. Wait for two seconds.

"Menu" appears on the panel display.

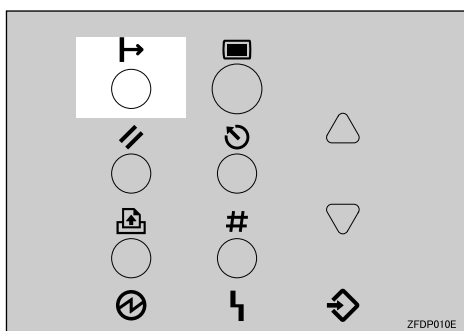
10 Press **[On Line]**.

"Ready" appears on the panel display.

```
Ready
```

Host Interface Menu

There are four menu items in the “Host Interface” menu.



- I/O Buffer
- I/O Timeout
- Network Setup
- IEEE 1394 Setup









Reference





For more information about the “Network Setup”, see “*Configuring the Printer for the Network*” in the Setup Guide.

For more information about the “IEEE 1394 Setup”, see “*Configuring the Printer for the Network*” in the Setup Guide.

Host Interface Parameters

Menu	Description
I/O Buffer	<p>You can set the size of the I/O Buffer. Normally it is not necessary to change this setting.</p> <p>16 KB, 32 KB, 64 KB, 128 KB, 256 KB, 512 KB</p> <p> Note</p> <p><input type="checkbox"/> Default: 128 KB</p>
I/O Timeout	<p>You can set how many seconds the printer should wait before ending a print job. If data from other port often appears in the middle of the print job, you should increase the timeout value.</p> <p>10 seconds, 15 seconds, 20 seconds, 25 seconds, 60 seconds</p> <p> Note</p> <p><input type="checkbox"/> Default: 15 seconds</p>

Menu	Description
Network Setup	<p>❖ IP Address You can set the IP Address.</p> <p> Note <input type="checkbox"/> Default: 011.022.033.044</p> <p>❖ Subnet Mask You can set the Subnet Mask.</p> <p> Note <input type="checkbox"/> Default: All zero</p> <p>❖ Gateway Address You can set the Gateway Address.</p> <p> Note <input type="checkbox"/> Default: All zero</p> <p>❖ Network Boot You can set how the Network Interface Board acquires TCP/IP settings.</p> <p> Note <input type="checkbox"/> Default: None</p> <p>❖ Frame Type (NW) You can set the Frame Type for NetWare.</p> <p> Note <input type="checkbox"/> Default: Auto</p> <p>❖ Active Protocol You can set the active protocol. TCP/IP, NetWare, NetBEUI, AppleTalk</p> <p> Reference Default: Active</p>
Network Setup	<p>❖ Ethernet You can select the speed of the network that the printer is connected to. Auto, 10 Mbps., 100 Mbps.</p> <p> Note <input type="checkbox"/> Default: Auto</p> <p> Reference For more information about Network Setup, see <i>“Configuring the Printer for the Network with the Control Panel”</i> in the Setup Guide.</p>

Menu	Description
IEEE 1394 Setup	<p>❖ IP Address1394 You can set the IP address for the IEEE 1394.</p> <p> Note <input type="checkbox"/> Default: 011.022.033.044</p> <p>❖ Subnet Mask1394 You can set the Subnet Mask for the IEEE 1394.</p> <p> Note <input type="checkbox"/> Default: All zero</p> <p>❖ IP over 1394 You can print with IP over 1394 function.</p> <p> Note <input type="checkbox"/> Default: Active</p> <p>❖ SCSI print You can print with SCSI print function.</p> <p> Note <input type="checkbox"/> Default: Active</p> <p> Reference For more information about IEEE 1394 Setup, see "<i>IEEE 1394 Configuration</i>" in the Setup Guide.</p>

Changing the Host Interface Menu

- 1 Press [Menu].

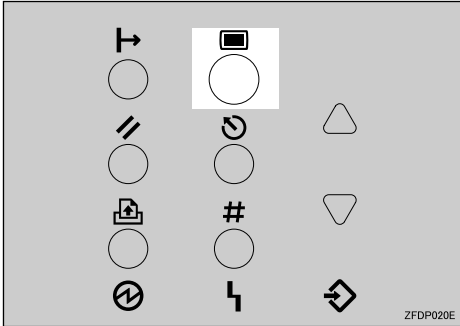

“Menu” appears on the panel display.

- 2 Press [▲] or [▼] to display the “Host Interface” menu.

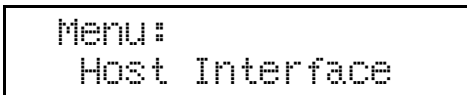

- 3 Press [Enter #].

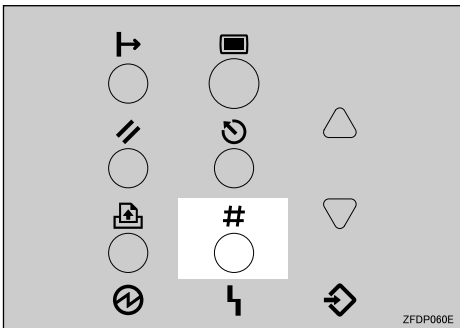

The following message appears on the panel display.

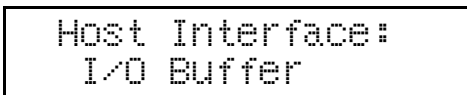

- 4 Press [▲] or [▼] to display “I/O Timeout”.

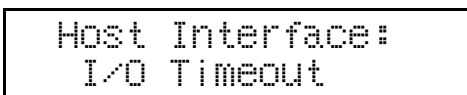

5 Press **[Enter #]**.

The following message appears on the panel display.

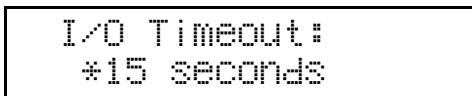

6 Press **[▲]** or **[▼]** to select how many minutes the printer waits before ending a print job.

7 Press **[Enter #]**. Wait for two seconds.

“Menu” appears on the panel display.

8 Press **[On Line]**.

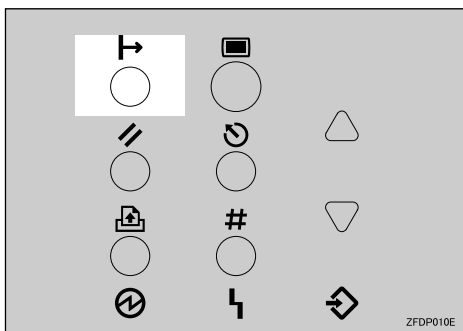

“Ready” appears on the panel display.







PCL Menu

There are seven menu items in the “PCL Menu” .

- Orientation
- Form Lines
- Font Source
- Font Number
- Point Size
- Font Pitch
- Symbol Set

PCL Parameters

Menu	Description
Orientation	<p>You can set the page orientation.</p> <ul style="list-style-type: none"> • Portrait • Landscape <p> Note</p> <p><input type="checkbox"/> Default: Portrait</p>
Form Lines	<p>You can set the number of lines per page.</p> <p>5-128</p> <p> Note</p> <p><input type="checkbox"/> Default: 64 (Metric version), 60 (Inch version)</p>
Font Source	<p>You can set the location of the default font.</p> <ul style="list-style-type: none"> • Resident • RAM • HDD <p> Note</p> <p><input type="checkbox"/> Default: Resident</p> <p><input type="checkbox"/> When you select "RAM", you can select only fonts downloaded to printer RAM.</p>
Font Number	<p>You can set the ID of the default font you want to use.</p> <ul style="list-style-type: none"> • 0 to 50 (for Internal) • 1 to Max.(For download source, Max is the amount of downloaded font) <p> Note</p> <p><input type="checkbox"/> Default: Internal</p> <p><input type="checkbox"/> Default: 0</p>

- 2** Press **[▲]** or **[▼]** to display "PCL Menu", and then press **[Enter #]**.

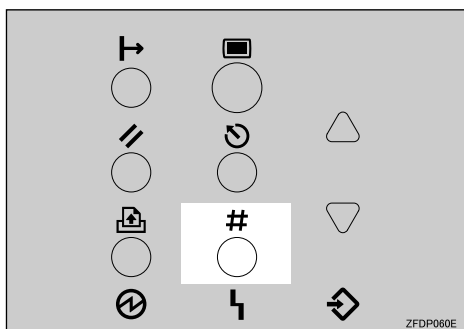

The following message appears on the panel display.

```
PCL Menu:
Orientation
```

- 3** Press **[Enter #]**.

```
Orientation:
*Portrait
```

- 4** Press **[▲]** or **[▼]** to select the orientation desired, and then press **[Enter #]**.
Wait for two seconds.

"Menu" appears on the panel display.

- 5** Press **[On Line]**.

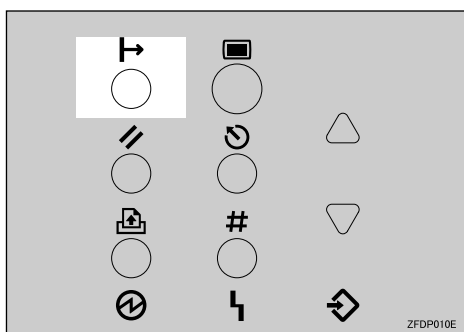

"Ready" appears on the panel display.

```
Ready
```

Language Menu

You can select the language you use. Available languages are as follows:

English, German, French, Italian, Dutch, Swedish, Norwegian, Danish, Spanish, Finnish, Portuguese, Czech, Polish, Hungarian

 **Note**

Default: English

Changing the Language Menu

You can change the language by the following procedures below.

1 Press **[Menu]**.

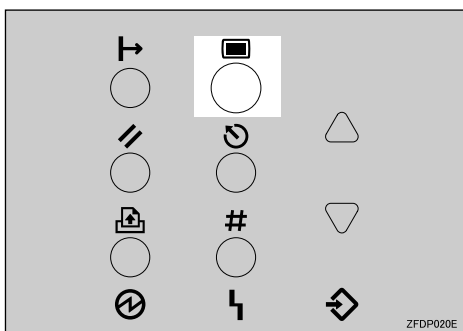

"Menu" appears on the panel display.

2 Press **[▲]** or **[▼]** to display "Language" menu.

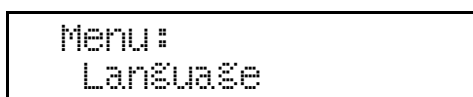

3 Press **[Enter #]**.

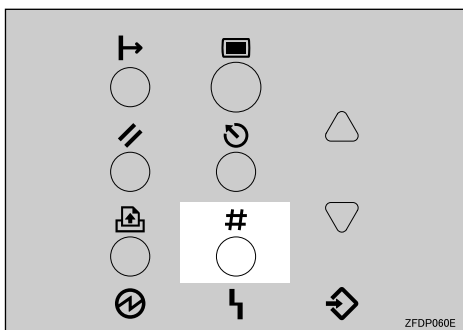

The following message appears on the panel display.

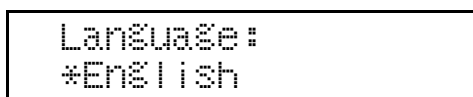

- 4** Press **[▲]** or **[▼]** until the language you want to select appears on the panel display.
- 5** Press **[Enter #]**. Wait for two seconds.
"Menu" appears on the panel display.
- 6** Press **[On Line]**.

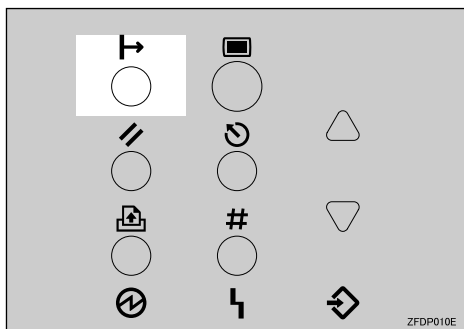

"Ready" appears on the panel display.









Stapling Position and Punch Position

You can select a stapling or punch position among those listed in the following table.

◆ Finisher SR720



- Stapling position

Feed direction	Orientation	Stapling position
	Portrait	 A
	Landscape	 A
	Portrait	 A
	Landscape	 A



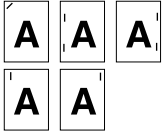
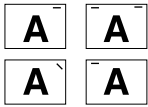

TAPY810E

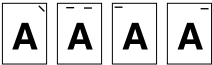
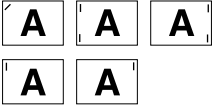
◆ **Finisher SR730**

• Stapling position

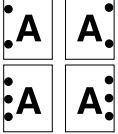
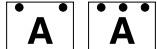
Feed direction	Orientation	Stapling position
	Portrait	
	Landscape	
	Portrait	
	Landscape	

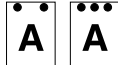
• Punch position

Feed direction	Orientation	Punch position
	Portrait	
	Landscape	
	Portrait	
	Landscape	

TAPY760E

Spool Printing

With spool printing, the whole data of a print job is saved in the Printer Hard Disk before printing. To use this function, set it from the menu. See p.116 "System Menu".

Important

- Do not turn off the printer or the computer when a print job is being spooled and the **Data In** indicator is blinking. If you do, the print job will remain in the Printer Hard Disk and be printed when the printer is turned on.

Limitation

- "Spool Printing" does not appear unless the optional Printer Hard Disk is installed.
- Data that has been received in the protocol other than LPD or IPP cannot be spooled.
- Up to 50 jobs (approximately 500 MB) can be spooled at a time.

Note

- When "On" is selected, the first print will take time.

Confirm or delete the spooled job from a Web browser.

The spooled job can be seen or deleted from a Web browser. Start a Web browser, and then input the IP address of the printer for URL to show the top page. Click **[Admin Info.]**, and then click **[Spool Printing]**. Select the file, check for delete, input the password, and then click the delete button. (The default password is "password".)

Paper Size and Resolution

The paper size and the resolution vary depending on the "Memory Usage" setting in the Maintenance menu, the memory capacity and other print settings. The following table shows relationship of paper size, memory capacity and resolution. The "Font Priority" uses memory for registering fonts. The "Frame Priority" uses memory for high speed printing.

With Frame Priority

Paper Size	Memory Capacity	Resolution (dpi)	
		300 x 300	600 x 600
A5	64 MB	⊙	⊙
	128 MB	⊙	⊙
B5	64 MB	⊙	⊙
	128 MB	⊙	⊙
A4/letter	64 MB	⊙	⊙
	128 MB	⊙	⊙
Legal	64 MB	⊙	⊙
	128 MB	⊙	⊙
B4	64 MB	⊙	⊙
	128 MB	⊙	⊙
A3/11 x 17 inches	64 MB	⊙	⊙*
	128 MB	⊙	⊙
Custom Size (297 x 600 mm/11.7 x 23.6 inches)	64 MB	⊙	○
	128 MB	⊙	○
Custom Size (297 x 1,260 mm/11.7 x 49.6 inches)	64 MB	⊙	○*
	128 MB	⊙	○

⊙: Supported for duplex/simplex printing.

○: Supported for simplex printing.

⊙*: Duplex printing may not be possible for the images with the compression rate under 3%.

○*: Printing may not be possible for the images with the compression rate under 3%.

With Font Priority

Paper Size	Memory Capacity	Resolution (dpi)	
		300 x 300	600 x 600
A5	64 MB	⊙	⊙
	128 MB	⊙	⊙
B5	64 MB	⊙	⊙
	128 MB	⊙	⊙
A4/letter	64 MB	⊙	⊙
	128 MB	⊙	⊙
Legal	64 MB	⊙	⊙
	128 MB	⊙	⊙
B4	64 MB	⊙	⊙*
	128 MB	⊙	⊙
A3/11 x 17 inches	64 MB	⊙	⊙*
	128 MB	⊙	⊙
Custom Size (297 x 600 mm/11.7 x 23.6 inches)	64 MB	⊙	○
	128 MB	⊙	○
Custom Size (297 x 1,260 mm/11.7 x 49.6 inches)	64 MB	⊙	○*
	128 MB	⊙	○

⊙: Supported for duplex/simplex printing.

○: Supported for simplex printing.

⊙*: Duplex printing may not be possible for the images with the compression rate under 3%.

○*: Printing may not be possible for the images with the compression rate under 3%.

Moving and Transporting the Printer

CAUTION:

- *When moving the machine, each person should hold the handles that are located on opposite sides, and then lift it slowly. Lifting it carelessly or dropping it may cause an injury.*
- *When you move the printer, remember to unplug the power cord from the wall outlet to avoid a fire or an electric shock.*
- *When you pull out the plug from the socket, grip the plug, not the cord, to avoid damaging the cord and causing a fire or an electric shock.*

Note

- The printer weighs approximately 63 kg (138.9 lb.).
- Repack the printer in its original packing materials for transporting.

Important

- Be sure to disconnect all cables from the printer before transporting it.
- The printer is a precision piece of machinery. Take care to avoid damage during shipment.

7

Moving the Printer

CAUTION:

- *When lifting the machine, use the grips on both sides. Otherwise the printer could break or cause an injury if dropped.*
- *Before moving the machine, unplug the power cord from the wall outlet. If the cord is unplugged abruptly, it could become damaged. Damaged plugs or cords can cause an electrical or fire hazard.*

Moving the printer in a short distance

1 Be sure to check the following points:

- The power switch is turned off.
- The power cable is unplugged from the wall outlet.
- The interface cable is unplugged from the printer.

2 If the external options are installed, remove them.

3 Lift the printer with two people by holding the handles, and then move it horizontally to the place where you want to install it.

4 If you removed options in step **2**, reinstall them.

⚠ Important

- Be sure to move the printer horizontally. To prevent toner from scattering, move the printer slowly.
- If the optional Paper Bank is installed, remove it from the printer, and then move them separately.

Specifications

Mainframe

❖ **Configuration:**

Desktop

❖ **Print Process:**

Laser beam scanning & Electrophotographic printing
Dualcomponent development

❖ **Printing Speed:**

Maximum 45 pages per minute (A4/letter), long edge feed, simplex/duplex

❖ **Parallel Interface:**

Interface

A standard 36-pin printer cable and a parallel port on the host computer

Mode

IEEE 1284 Compatible, ECP, Nibble

❖ **Network Cable:**

10BASE-T/100BASE-TX shielded twisted-pair (STP) cable

❖ **Network:**

Topology

Ethernet 10BASE-T/100BASE-TX

Protocol

IPX/SPX, TCP/IP, AppleTalk, IPP, NetBEUI (only with SmartNetMonitor)

❖ **Resolution:**

600 × 600 dpi (PCL 5e, PCL 6, PS, TIFF)

400 × 400 dpi (TIFF)

300 × 300 dpi (PCL 5e, PS, TIFF)

200 × 200 dpi (TIFF)

❖ **Printer Language:**

PCL 5e, PCL 6 (5e+XL), Adobe PostScript 3, RPCS

- Automatic language switching (Auto Sense)

❖ **Fonts:**

PCL 5e, PCL 6

35 Intellifonts, 10 True Type fonts, and 1 Bitmap font
Font Manager available, plus 61 additional fonts.

PostScript

136 Adobe Type 1 fonts

❖ **Paper size:**
⇒ p.25 “Paper and Other Media Supported by This Printer”

❖ **Paper Weight:**
⇒ p.25 “Paper and Other Media Supported by This Printer”

❖ **Power Source:**
⇒ inside of the front cover of this manual

❖ **Power Consumption:**

❖ **For Europe/Asia**

	Mainframe only	With full options
Maximum	1,350 W or less	1,450 W or less
Printing	790 W or less	870 W or less
Energy Saver Mode	9 W or less	9 W or less

❖ **For North America**

	Mainframe only	With full options
Maximum	1,280 W or less	1,400 W or less
Printing	770 W or less	850 W or less
Energy Saver Mode	8 W or less	8 W or less

❖ **Noise Emission ^{*1} :**

❖ **Sound Power Level**

	Mainframe only
During printing	70 dB (A)
Stand-by	42 dB (A)

❖ **Sound Pressure Level ^{*2}**

	Mainframe only
During printing	58 dB (A)

^{*1} The above measurements made in accordance with ISO 7779 are actual value.

^{*2} It is measured at the position of the bystander.

❖ **Dimensions:**

	Width	Depth	Height
Printer only (Bypass Tray not extended)	670 mm (26.4 inches)	640 mm (25.2 inches)	560 mm (22.4 inches)
Printer with paper bank (Bypass Tray not extended)	670 mm (26.4 inches)	640 mm (25.2 inches)	820 mm (32.3 inches)
Printer with full options *1 (Bypass Tray extended)	2,140 mm (84.3 inches)	640 mm (25.2 inches)	970 mm (38.2 inches)

*1 Finisher SR730, Mailbox CS360, Bridge Unit Type1045, Large Capacity Tray RT36 and Paper Bank PS430.

❖ **Weight:**

Approximately 63 kg (138.9 lb) (power cord included)

❖ **Warm-up Time:**

Less than 22 seconds (20 °C/68 °F)

Less than 15 seconds from Energy Saver mode (20 °C/68 °F)

❖ **Paper Capacity:**

Standard paper tray	500 sheets × 2 *1
Bypass Tray	50 sheets *1
Optional Paper Bank	500 sheets × 2 *1
Optional Large Capacity Tray	1,500 sheets *1

*1 Paper weight: 80 g/m², 20 lb. bond

❖ **Paper Output Capacity:**

500 sheets (80 g/m², 20 lb. bond)

If the paper is curled or if you use the guides, the output capacity is reduced.

❖ **Memory:**

Standard 64 MB, up to 320 MB (with SIMM module)

❖ **Options:**

- Paper Bank PS430
- Large Capacity Tray RT36
- Finisher SR720
- Finisher SR730
- Punch Kit Type450
- Mailbox CS360
- Bridge Unit Type1045
- Bridge Unit Type460
- Printer Hard Disk Type 4510
- 1394 Interface Unit Type 4510

- Memory Unit Type C 64MB, Memory Unit Type C 128MB, Memory Unit Type C 256MB
- Barcode Font DIMM Type A

Options

Paper Bank PS430

- ❖ **Paper size:**
⇒ p.25 “Paper and Other Media Supported by This Printer”
 - ❖ **Paper weight:**
⇒ p.25 “Paper and Other Media Supported by This Printer”
 - ❖ **Maximum power consumption:**
50 W (power is supplied from the main frame.)
 - ❖ **Paper capacity:**
⇒ p.25 “Paper and Other Media Supported by This Printer”
 - ❖ **Dimensions (W × D × H):**
540 × 600 × 270 mm (21.3 × 23.7 × 10.7 inches)
 - ❖ **Weight:**
Approx. 25 kg (55.2 lb.)
-  **Note**
 Specifications are subject to change without notice.

Large Capacity Tray RT36

- ❖ **Paper size:**
⇒ p.25 “Paper and Other Media Supported by This Printer”
- ❖ **Paper weight:**
⇒ p.25 “Paper and Other Media Supported by This Printer”
- ❖ **Paper capacity:**
⇒ p.25 “Paper and Other Media Supported by This Printer”
- ❖ **Power consumption:**
Approx. 40 W (power is supplied from the main frame.)
- ❖ **Dimensions (W × D × H):**
390 × 500 × 390 mm (15.4 × 19.7 × 15.4 inches)
- ❖ **Weight:**
Approx. 17 kg (37.5 lb.)

Finisher SR720

❖ Paper size:

A3, B4 JIS, A4, B5 JIS, A5, A6, 11 × 17 inches, legal, letter, 5¹/₂ × 8¹/₂ inches, 7¹/₄ × 10¹/₂ inches, 8¹/₄ × 13 inches, 8¹/₂ × 13 inches, 8 × 13 inches

❖ Paper weight:

52 – 157 g/m² (14 – 42 lb. bond)

❖ Stack capacity:

- 1,000 sheets (A4/letter or smaller) (80 g/m², 20 lb. bond)
- 500 sheets (B4 JIS, legal or larger) (80 g/m², 20 lb. bond)

❖ Staple capacity:

- 30 sheets (A4/letter or smaller) (80 g/m², 20 lb. bond)
- 20 sheets (B4 JIS, legal or larger) (80 g/m², 20 lb. bond)

❖ Staple paper size:

A3, B4 JIS, A4, B5 JIS, 11 × 17 inches, legal, letter

❖ Staple paper weight:

64 – 80 g/m² (17 – 20 lb. bond)

❖ Staple position:

⇒ p.133 “Stapling Position and Punch Position”

❖ Power consumption:

48 W (power is supplied from the main frame.)

❖ Dimensions (W × D × H):

568 × 520 × 625 mm (22.4 × 20.5 × 24.6 inches)

❖ Weight:

Approx. 21 kg (46.3 lb.)

Finisher SR730

Shift Tray:
❖ Paper size:

A3, B4 JIS, A4, B5 JIS, A5, A6, 11 × 17 inches, legal, letter, 5¹/₂ × 8¹/₂ inches, 7¹/₄ × 10¹/₂ inches, 8¹/₄ × 13 inches, 8¹/₂ × 13 inches, 8 × 13 inches

❖ Paper weight:

52 – 157 g/m² (14 – 42 lb. bond)

❖ **Stack capacity:**

without punch:

- 3,000 sheets (A4/letter \square) (80 g/m², 20 lb. bond)
- 1,500 sheets (A3 \square , B4 JIS \square , A4 \square , B5 JIS \square \square , 11 × 17 inches \square , legal \square , letter \square) (80 g/m², 20 lb. bond)

with punch (the optional punch kit is required):

- 2,500 sheets (A4/letter \square) (80 g/m², 20 lb. bond)
- 1,500 sheets (A3 \square , B4 JIS \square , A4 \square , B5 JIS \square \square , 11 × 17 inches \square , legal \square , letter \square) (80 g/m², 20 lb. bond)

Proof Tray:

❖ **Paper size:**

A3 \square , B4 JIS \square , A4 \square \square , B5 JIS \square \square , A5 \square , A6 \square , 11 × 17 inches \square , legal \square , letter \square \square , 5¹/₂ × 8¹/₂ inches \square , 7¹/₄ × 10¹/₂ inches \square , 8¹/₄ × 13 inches \square , 8¹/₂ × 13 inches \square , 8 × 13 inches \square

❖ **Paper weight:**

52 – 157 g/m² (14 – 42 lb. bond)

❖ **Stack capacity:**

without punch:

- 250 sheets (A4/letter \square \square or smaller) (80 g/m², 20 lb. bond)
- 50 sheets (B4 JIS \square , legal \square or larger) (80 g/m², 20 lb. bond)

with punch (the optional punch kit is required):

- 200 sheets (A4/letter \square \square or smaller) (80 g/m², 20 lb. bond)
- 50 sheets (B4 JIS \square , legal \square or larger) (80 g/m², 20 lb. bond)

Staple:

❖ **Staple capacity:**

without punch:

- 50 sheets (A4/letter \square \square or smaller) (80 g/m², 20 lb. bond)
- 30 sheets (B4 JIS \square , legal \square or larger) (80 g/m², 20 lb. bond)

with punch (the optional punch kit is required):

- 40 sheets (A4/letter \square \square or smaller) (80 g/m², 20 lb. bond)
- 25 sheets (B4 JIS \square , legal \square or larger) (80 g/m², 20 lb. bond)

❖ **Staple paper size:**

A3 \square , B4 JIS \square , A4 \square \square , B5 JIS \square \square , 11 × 17 inches \square , letter \square \square , legal \square , 7¹/₄ × 10¹/₂ inches \square , 8¹/₄ × 13 inches \square , 8¹/₂ × 13 inches \square , 8 × 13 inches \square

❖ **Staple paper weight:**

64 – 80 g/m² (17 – 20 lb. bond)

❖ **Staple position:**

⇒ p.133 “Stapling Position and Punch Position”

❖ **Power consumption:**

48 W (power is supplied from the main frame.)

❖ **Dimensions (W × D × H):**

625 × 545 × 960 mm (24.7 × 21.5 × 37.8 inches)

❖ **Weight:**

Approx. 45 kg (99.3 lb.)

Punch Kit Type450 **Note**

□ Optional unit for the Finisher SR730.

❖ **Paper size (2 holes version):**

A3[□], B4 JIS[□], A4^{□□}, B5 JIS^{□□}, A5^{□□}, 11 × 17 inches[□], letter^{□□}, 5¹/₂ × 8¹/₂ inches^{□□}, legal[□], 7¹/₄ × 10¹/₂ inches[□], 8¹/₄ × 13 inches[□], 8¹/₂ × 13 inches[□], 8 × 13 inches[□]

❖ **Paper size (3 holes version):**

A3[□], B4 JIS[□], A4[□], B5 JIS[□], 11 × 17 inches[□], letter[□]

❖ **Paper weight:**

- 2 holes version: 52 – 128 g/m² (14 – 34 lb. bond)
- 3 holes version: 52 – 105 g/m² (14 – 28 lb. bond)

❖ **Punch position:**

⇒ p.133 “Stapling Position and Punch Position”

❖ **Power consumption:**

33.6 W (power is supplied from the 3000–sheet Finisher.)

❖ **Dimensions (W × D × H):**

92 × 463 × 100 mm (3.7 × 18.3 × 4.0 inches)

❖ **Weight:**

2.4 kg (5.3 lb.)

Mailbox CS360

❖ Number of trays:

9 bins, 1 Proof Tray

❖ Paper size:

Bin 1 to 9:

A3, B4 JIS, A4, B5 JIS, A5, 11 × 17 inches, legal, letter, 5¹/₂ × 8¹/₂ inches, 7¹/₄ × 10¹/₂ inches, 8¹/₄ × 13 inches, 8¹/₂ × 13 inches, 8 × 13 inches

Proof Tray:

A3, B4 JIS, A4, B5 JIS, A5, A6, 11 × 17 inches, legal, letter, 5¹/₂ × 8¹/₂ inches, 7¹/₄ × 10¹/₂ inches, 8¹/₄ × 13 inches, 8¹/₂ × 13 inches, 8 × 13 inches

❖ Paper weight:

Bin: 60 to 90 g/m² (16 to 24 lb. bond)

Proof: 52 to 157 g/m² (14 to 42 lb. bond)

❖ Paper capacity:

Bin: 100 sheet per tray (A4, letter, 80 g/ m², 20 lb. bond) / 70 sheets per tray (Others)

Proof: 500 sheet per tray (A4, letter, 80 g/ m², 20 lb. bond) / 300 sheets per tray (Others)

❖ Power consumption:

48 W

❖ Dimensions (W × D × H):

600 × 545 × 980 mm (23.7 × 21.5 × 38.6 inches)

❖ Weight:

Approx. 37 kg (82 lb.)

Printer Hard Disk Type 4510

❖ Storage capacity:

10 GB or more

INDEX

A

Auto Continue, 116

B

Bypass size, 104

C

cable, 140
Config. Page, 108
Counter, 102

D

Data In indicator, 76
Duplex, 116

E

Edge Smoothing, 116
Energy Saver, 116
Envelopes, 30
error, 55
Escape key, 102

F

Finisher SR720, 91, 94, 144
Finisher SR730, 92, 95, 144
Font Number, 127
Font Pitch, 127
fonts, 140
Font Source, 127
Form Lines, 127

H

HDD Format, 112
Hex Dump, 108
Host Interface, 102, 122

I

IEEE 1394 Setup, 122
Image density, 112
I/O Buffer, 122
I/O Timeout, 122

J

Job Separation, 116

L

Language, 102, 130
Large Capacity Tray RT36, 143
List/Test Print, 102, 108
List/Test Print Parameters, 108
Loading Paper, 29
Locked Print, 49, 102

M

Mailbox CS360, 147
Maintenance, 102, 112
media, 25, 33
memory, 136, 142
Memory Overflow, 116
Memory Usage, 116
menu, accessing, 102
menu, changing, 130
Menu Chart, 99
Menu key, 102
Menu List, 108
Menu Protect, 112
messages, 55
misfeed, 80
MisfeedRecovery, 116
Moving the Printer, 138

N

network, 140
Network Printing Guide, ii
Network Setup, 122

O

OHP transparencies, 30
On Line key, 75, 103
options, 142, 143
Orientation, 127
Output Tray, 116

P

Page Size, 116
panel display, messages, 55
paper, 25, 33
paper bank, 143
Paper Input, 102, 104
paper sizes, 25
Paper type, 104
PCL, 127
PCL 5e
 Windows 2000, uninstalling, 19
 Windows 95/98/Me, uninstalling, 19
 Windows NT 4.0, uninstalling, 20
PCL 6
 Windows 2000, uninstalling, 19
 Windows 95/98/Me, uninstalling, 19
 Windows NT 4.0, uninstalling, 20
PCL Config. Page, 108
PCL Menu, 102
Plain Paper, 29
Point Size, 127
PostScript
 Windows 2000, uninstalling, 23
 Windows 95/98/Me, uninstalling, 23
 Windows NT 4.0, uninstalling, 24
Printable Area, 32
Printer Hard Disk Type 4510, 147
Printer Reference, ii
Prt. Err Report, 116
PS430, 143
PS Config. Page, 108
punch, 133
Punch Kit Type450, 146

Q

Quick Installation Guide, ii

R

Registration, 112
Resolution, 116
RPCS
 Windows 2000, uninstalling, 21
 Windows 95/98/Me, uninstalling, 21
 Windows NT 4.0, uninstalling, 22

S

Sample Print, 45, 102
Setup Guide, ii
SIMM, 142
specifications, 140
Spool Printing, 116
staple, 91, 94, 133
Storing Paper, 29
Sub Paper Size, 116
Symbol Set, 127
System, 102, 116

T

Thick Paper, 30
toner bottle, 97
Toner Saving, 116
Tray Locking, 104
Tray Paper Size, 104
Tray Priority, 104
troubleshooting, 55

U

Unit Of Measure, 116

W

Windows 2000

- canceling a job*, 15
- PCL 5e, uninstalling*, 19
- PCL 6, uninstalling*, 19
- PostScript, uninstalling*, 23
- printer properties, PCL*, 2
- printer properties, PostScript*, 10
- printer properties, RPCS*, 6
- RPCS, uninstalling*, 21

Windows 95/98/Me

- canceling a job*, 14
- PCL 5e, uninstalling*, 19
- PCL 6, uninstalling*, 19
- PostScript, uninstalling*, 23
- printer properties, PCL*, 1
- printer properties, PostScript*, 9
- printer properties, RPCS*, 5
- RPCS, uninstalling*, 21

Windows NT 4.0

- canceling a job*, 16
- document defaults, PCL*, 4
- document defaults, PostScript*, 12
- document defaults, RPCS*, 8
- PCL 5e, uninstalling*, 20
- PCL 6, uninstalling*, 20
- PostScript, uninstalling*, 24
- printer properties, PCL*, 3
- printer properties, PostScript*, 11
- printer properties, RPCS*, 7
- RPCS, uninstalling*, 22

Addendum

This manual describes necessary information about using this machine.

Notes to Windows XP Users

- The printer driver ^{*1} for Windows 2000 can be used with Windows XP Professional and Windows XP Home Edition.
- When you install the printer driver in Windows XP, the **[Hardware Installation]** dialog box may appear. In this case, click **[Continue Anyway]** to continue the installation.

*1 The RPCS driver does not support Fast User Switching function.

Note

- You can set a port using TCP/IP and the IEEE 1394 (IP over 1394) interface. For more information, see the manual that comes with the 1394 Interface Unit.
-

Notes to Windows Me Users

You cannot print with IP over 1394 by following the "Printing with IP over 1394" setting method in the manual that comes with the machine.

Reference

For more information about how to make settings, see the manual that comes with the 1394 Interface Unit.

Appendix

This section provides information that is not in the Printer Reference.

Making Printer Settings with the Control Panel

❖ System Menu

Menu	Description
Edge-Edge Print	You can print on the complete area of an A4 sheet leaving no border on any edge.  Note <input type="checkbox"/> Default: Off

❖ PCL Menu

Menu	Description
Ext. A4 Width	You can extend the width of the printable area for an A4 sheet leaving a narrow margin on the sides.  Note <input type="checkbox"/> Default: Off